

ШВЕЙПРОМ

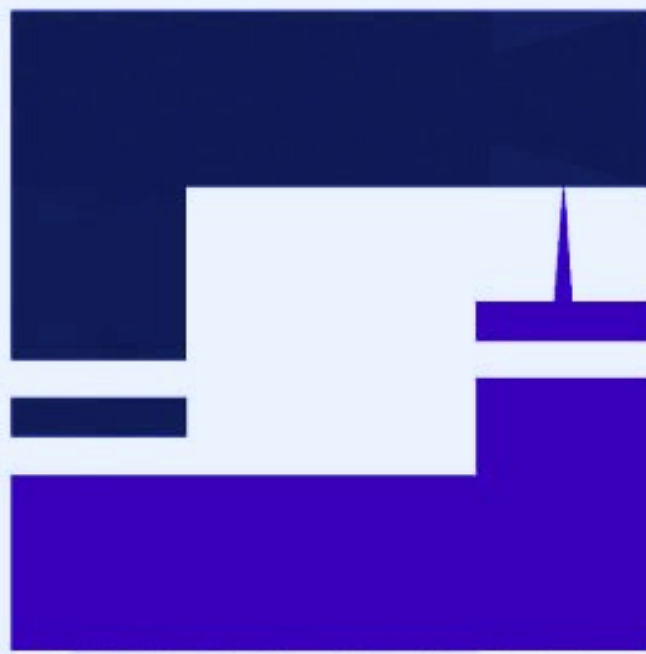

КОМПЛЕКТ

Данная информация для
Вас предоставлена
ООО "ШВЕЙПРОМКОМПЛЕКТ"
т/ф (499) 2592598 г.Москва
www.shveiprom.com
2592598@mail.ru

PARTS BOOK

FOR 1-NEEDLE,
STRAIGHT LOCK-STITCH MACHINE SERIES

KM-250AU-7S	KM-250AU-7N
KM-250A-7S	KM-250A-7N
KM-250B-7S	KM-250B-7N
KM-250BH-7S	KM-250BH-7N
KM-250BL-7S	KM-250BL-7N
KM-250AU	KM-250A
KM-250B	KM-250BH
KM-250BL	



MODEL

FOR NEW MATERIAL AND EXTREME THIN MATERIAL

- **KM-250AU-7S**
1-NEEDLE, STRAIGHT LOCK-STITCH MACHINE
WITH THREAD TRIMMER DRIVEN BY SERVO MOTOR
- **KM-250AU-7N**
1-NEEDLE, STRAIGHT LOCK-STITCH MACHINE
WITH THREAD TRIMMER DRIVEN BY NEEDLE POSITIONING MOTOR
- **KM-250AU**
1-NEEDLE, STRAIGHT LOCK-STITCH MACHINE

FOR THIN MATERIAL

- **KM-250A-7S**
1-NEEDLE, STRAIGHT LOCK-STITCH MACHINE
WITH THREAD TRIMMER DRIVEN BY SERVO MOTOR
- **KM-250A-7N**
1-NEEDLE, STRAIGHT LOCK-STITCH MACHINE
WITH THREAD TRIMMER DRIVEN BY NEEDLE POSITIONING MOTOR
- **KM-250A**
1-NEEDLE, STRAIGHT LOCK-STITCH MACHINE

FOR THICK MATERIAL

- **KM-250B-7S**
1-NEEDLE, STRAIGHT LOCK-STITCH MACHINE
WITH THREAD TRIMMER DRIVEN BY SERVO MOTOR
- **KM-250B-7N**
1-NEEDLE, STRAIGHT LOCK-STITCH MACHINE
WITH THREAD TRIMMER DRIVEN BY NEEDLE POSITIONING MOTOR
- **KM-250B**
1-NEEDLE, STRAIGHT LOCK-STITCH MACHINE

FOR HEAVY MATERIAL

- **KM-250BH-7S**
1-NEEDLE, STRAIGHT LOCK-STITCH MACHINE
WITH THREAD TRIMMER DRIVEN BY SERVO MOTOR
- **KM-250BH-7N**
1-NEEDLE, STRAIGHT LOCK-STITCH MACHINE
WITH THREAD TRIMMER DRIVEN BY NEEDLE POSITIONING MOTOR
- **KM-250BH**
1-NEEDLE, STRAIGHT LOCK-STITCH MACHINE

FOR HEAVY MATERIAL

- **KM-250BL-7S**
1-NEEDLE, STRAIGHT LOCK-STITCH MACHINE
WITH THREAD TRIMMER DRIVEN BY SERVO MOTOR & LARGE HOOK
- **KM-250BL-7N**
1-NEEDLE, STRAIGHT LOCK-STITCH MACHINE
WITH THREAD TRIMMER DRIVEN BY NEEDLE POSITIONING MOTOR & LARGE HOOK
- **KM-250BL**
1-NEEDLE, STRAIGHT LOCK-STITCH MACHINE WITH LARGE HOOK

CONTENTS

목 차

A	<i>Machine Body & Thread Tension Adjusting Mechanism</i> 외장 및 실장력 조절관계	4
B	<i>Upper Shaft & Needle Bar Mechanism</i> 상축 및 바늘대 관계	6
C	<i>Upright Shaft & Lower Shaft Mechanism</i> 세운 축 및 하축 관계	8
D	<i>Feed Mechanism</i> 피이드 관계	10
E	<i>Thread Trimmer Mechanism</i> 사절관계	14
F	<i>Presser Foot & Tension Release Mechanism</i> 노루발 및 실 늦추기 관계.....	16
G	<i>Thread Wiper Mechanism</i> 와이퍼 관계	18
H	<i>Reverse Wiper Mechanism</i> 역진 보턴 관계.....	20
I	<i>Lubrication</i> 급유관계	21
J	<i>Accessories</i> 약세사리	22
K	<i>Program Unit Box & Auto Presser Lifting Solenoid Mechanism(Option Parts: SPF-5)</i> 프로그램 유닛 박스 및 자동 무릎올림 관계	24
L	<i>Special Parts For KM-250AU Series</i> KM-250AU 시리즈 전용부품관계.....	25
M	<i>Special Parts For (KM-250AU-7N, KM-250A-7N, KM-250B-7N)</i> [KM-250AU-7N, KM-250A-7N, KM-250B-7N] 전용부품관계.....	26
N	<i>Special Parts For KM-250BH Series</i> KM-250BH 시리즈 전용부품관계	27
O	<i>Special Parts For KM-250BL Series</i> KM-250BL 시리즈 전용부품관계	28
P	<i>Special Parts For KM-250BL Series</i> KM-250BL 시리즈 전용부품관계	30

NOTE : Parts are Subject to Change in Design Without Prior Notice.

A

Machine Body & Thread Tension Adjusting Mechanism 외장 및 실장력 조절관계

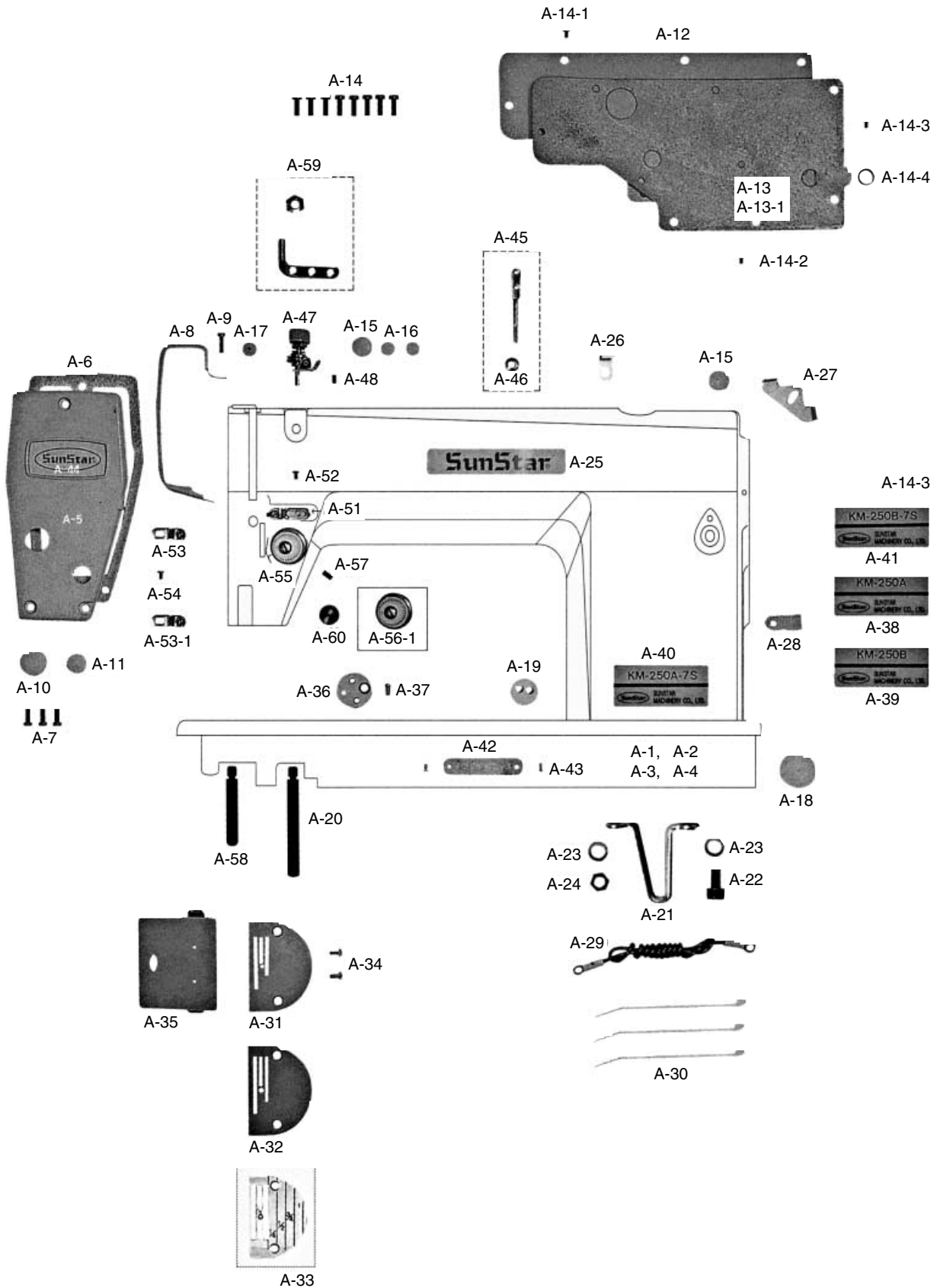

Ref. No.	Parts No.	Note	Name of Parts	품명	Q'ty	Assembly No.
A-1	01-001A-250A	A	Arm. Bed	아암베드	1	
A-2	01-001A-250B	B	Arm. Bed	아암베드	1	
A-3	01-001A-257A	A-7	Arm. Bed	아암베드	1	
A-4	01-001A-257B	B-7	Arm. Bed	아암베드	1	
A-4-1	01-001A-25BL		Arm. Bed	아암베드	1	
A-4-2	01-001A-2BLS		Arm. Bed	아암베드	1	
A-5	01-036C-2500		Face Plate	면판	1	
A-6	01-137M-2500		Gasket For A-5	면판 가스켓	1	
A-7	SC-0523-1230		Screw(3/16" n=28)	무릎올림 링크 고정나사(3/16" n=28)	3	
A-8	01-139C-2500		Thread Take Up Cover	실채기 커버	1	
A-9	SC-0548-7400		Screw(3/16" n=28)	다이알 판 쥘나사(3/16" n=28)	1	
A-10	01-144R-1230		Face Plate Rubber Cap(L)	면판 고무마개(大) 흰색(3-1)	1	
A-11	01-110R-1230		Face Plate Rubber Cap(S)	면판 고무마개(中) 흰색(3)	1	
A-12	01-140C-2500		Back Cover	뒷뚜껑(STD)	1	
A-13	01-141M-2500		Gasket For A-12	뒷뚜껑 가스켓(ST)	1	
A-13-1	01-142M-2500		Gasket For A-12	뒷뚜껑 가스켓(AK)	1	
A-14	SC-0548-7400	A, B	Screw(3/16" n=28)	다이알판 쥘나사(3/16" n=28)	8	
A-14-1	SC-0523-1230	A-7, B-7	Screw(3/16" n=28)	무릎올림 링크 고정나사	3	
A-14-2	SC-0548-7400	A-7, B-7	Screw(3/16" n=28)	다이알판 쥘나사	5	
A-14-3	SC-0215-1230	A-7, B-7	Screw(9/64" n=40)	톱카바 나사(좌)	1	
A-14-4	02-019W-1230	A-7, B-7	Washer	상축 헬트 와셔	1	
A-15	01-110R-1230		Arm Rubber Cap(L)	면판 고무마개(中) 흰색(3)	2	
A-16	01-003R-1600		Arm Rubber Cap(S)	바늘대 상붓싱 마개(흰색)40	2	
A-17	04-003R-1600	A-7, B-7	Rubber Cap For B-40	바늘대 상붓싱 마개	1	
A-18	01-021R-1600		Bed Rubber Cap	하축 후붓싱 고무마개	1	
A-19	01-005A-257A		Code Bushing	코드 붓싱	1	
A-20	01-016C-1230		Bed Base "FRONT"(A-TYPE)	베드 받침(전)	1	
A-21	01-115C-1230		Bed Base(R)	베드 받침	1	
A-22	SC-0346-2350		Screw(M8×1.25)	베드 받침 후 결합 볼트(M8×1.25)	1	
A-23	01-038W-1230		Spring Washer For A-21	베드 받침 스프링 와셔	2	
A-24	SN-0112-1230	A-7, B-7	Nut(M8×1.25)	베드 받침 너트(M8×1.25)	1	
A-25	01-010M-2350	A-7, B-7	Brand Mark	상표 마크	1	
A-26	01-142A-257A	A-7, B-7	Code Holder "A"	코드잡이 "A"	1	
A-27	01-143A-257A	A-7, B-7	Code Holder "B"	코드잡이 "B"	1	
A-28	01-009R-5300	A-7, B-7	Code Holder(7N)	케이블 잡이A(7N)	1	
A-29	12-016M-2350	A, A-7	Earth Line	어스선(조)	1	
A-30	02-003A-2700	B, B-7	Nylon Clip	나이론 클립	3	
A-31	01-135A-123A	A, A-7	Needle Plate(A-TYPE)	바늘판(A形)	1	
A-32	01-135A-123B	B, B-7	Needle Plate(B-TYPE)	바늘판(B形)	1	
A-33	06-135A-235B		Needle Plate(BH-TYPE)	침판(마그린)	1	
A-34	01-136S-1230		Screw(11/64" n=40)	침판나사(11/64" n=40)	2	
A-35	01-434A-1230		Slide Plate	미끄럼판(組)	1	
A-36	01-044A-257A	A	Gauge Plate	게이지 부착판	1	
A-37	01-136S-1230		Screw(11/64" n=40)	침판나사(11/64" n=40)	1	
A-38	01-045M-250A	A-7	Model Mark(KM-250A)	모델마크(KM-250A)	1	
A-39	01-045M-250B	B-7	Model Mark(KM-250B)	모델마크(KM-250B)	1	
A-40	01-045M-257A		Model Mark(KM-250A-7S)	모델마크(KM-250A-7S)	1	
A-41	01-045M-257B		Model Mark(KM-250B-7S)	모델마크(KM-250B-7S)	1	
A-42	01-035P-1370		Machine Number Plate	번호판	1	
A-43	01-035P-7400		Pin	번호판 핀	2	
A-44	01-038M-2500		Brand Mark	면판 마크	1	
A-45	01-116A-2350	A-7, B-7	Upper Thread Guide Pin and Nut	실 안내봉	1	
A-46	01-027C-1230	A-7, B-7	Nut For A-45	세구멍 실걸이 너트	1	
A-47	40-201A-2700	A, B	Sub Upper Thread Tension Control Ass'y	보조 사조자	1조	
A-48	SC-0542-1230	A, B	Screw(11/64" n=40)	실 늦추기 고정나사(11/64" n=40)	1	
A-51	01-030C-1230	A, A-7	Arm Thread Guide	암 실걸이	1	
A-52	SC-0120-1230	B, B-7	Screw(9/64" n=40)	오일 펌프 카바 나사(9/64" n=40)	1	
A-53	01-031C-1230		Thread Guide For A-5	면판 실걸이	1	
A-53-1	01-003C-250B	A, A-7	Thread Guide For A-5	면판 실걸이	1	
A-54	SC-0120-1230	B, B-7	Screw(9/64" n=40)	오일 펌프 카바 나사(9/64" n=40)	1	
A-55	40-104A-2350	B, B-7	Thread Tension Control Ass'y	실조절장치	1조	
A-56-1	40-004A-250B		Thread Tension Control Ass'y	실조절장치(組):B形	(1조)	
A-56-2	40-333G-123B	A, B	Thread Tension Adjusting Spring	소라스프링(123B)	(1)	A-56
A-57	SC-0114-1230	A, B	Screw(15/64" n=28)	실채기 힌지핀 나사(15/64" n=28)	1	
A-58	01-017C-1230		Bed Base "FRONT"(B)	베드 받침(후)	1	
A-59	01-027A-1230		Thread Guide With Three Holes	세구멍 실걸이(조)	1	
A-60	40-008R-1230		Cap For Tension Release Pin	누유방지용 캡	1	

NOTE:

A-7=KM-250A-7S
 B-7=KM-250B-7S
 A=KM-250A
 B=KM-250B
=Common Part

B

Upper Shaft & Needle Bar Mechanism 상축 및 바늘대 관계

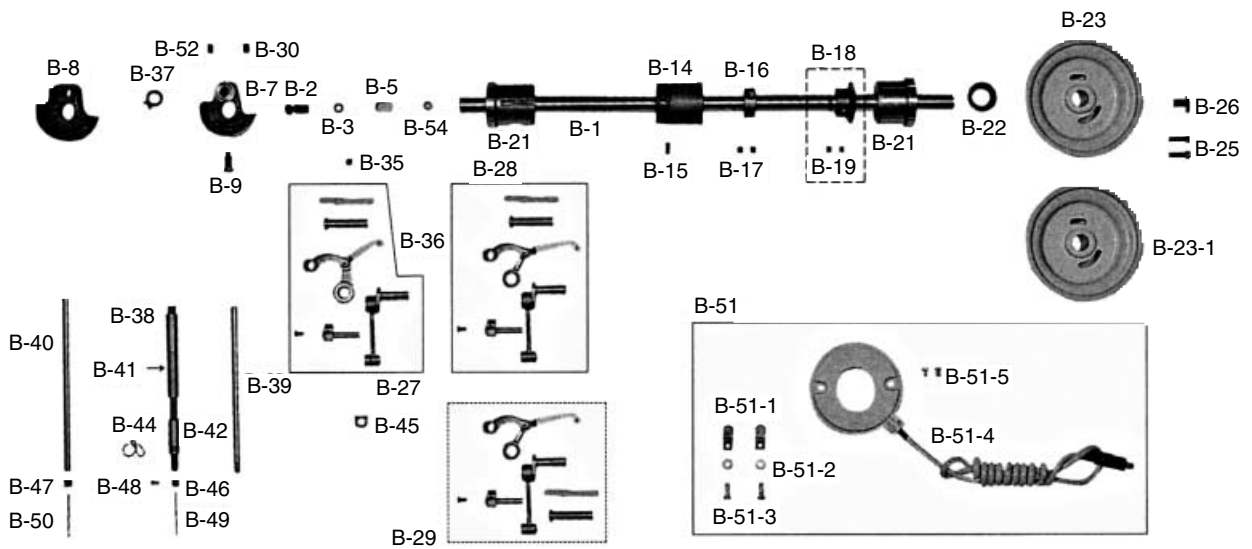

Ref. No.	Parts No.	Note	Name of Parts	품 명	Q' ty	Assembly No.
B-1	02-101A-2500		Upper Shaft	상축(SERVO용:L=419.5mm)	1	
B-2	02-115C-2500		Oil Adjusting Pin For B-1	상축 유량 조절핀(137&235)	1	
B-3	02-016R-1230		O-Ring For B-2	상축 유량 조절핀 오링	1	
B-5	02-020M-1230		Upper Shaft Felter	상축 펠트	1	
B-7	02-102A-250A	A, A-7	Link Cam(A-TYPE)	링크 캠(A形)	1	
B-8	02-102A-250B	B, B-7	Link Cam(B-TYPE)	링크 캠(B形)	1	
B-9	SC-0123-1230		Screw(9/32" n=28)	링크 캠 위치 고정나사(9/32" n=28)	1	
B-12	02-104A-250A		Upper Shaft Bushing(F)	상축 전봇싱	1	
B-14	02-105A-2500		Upper Shaft Bushing(M)	상축 중봇싱	1	
B-15	SC-0114-1230		Screw(15/64" n=28)	실체기 힌지핀 나사(15/64" n=28)	1	
B-16	02-121A-1230		Upper Shaft Collar	상축 카라	1	
B-17	SC-A129-4515		Screw(1/4" n=40)	홈볼이 멈춤나사(1/4" n=40)	2	
B-18	02-211A-1230		Upper Shaft Gear	상축 기어	1	
B-19	SC-A129-4515		Screw(1/4" n=40)	홈볼이 멈춤나사(1/4" n=40)	2	
B-21	02-106A-257B		Upper Shaft Bushing(R)	상축 후봇싱	1	
B-22	02-028C-1230		Oil Seal For B-20,21	상축 오일셀	1	
B-23	02-207A-257A	A-7, B-7	Pulley(Only For Trimming M/C)	폴리	1	
B-23-1	02-207A-257A	A, B	Pulley(Only For Regular M/C)	폴리	1	
B-25	SC-0150-2500		Screw(15/64" n=28)	폴리 고정나사(15/64" n=28)	2	
B-26	SC-0188-1230		Screw(5/16" n=24)	폴리 큰나사(5/16" n=24)	1	
B-27	08-201A-250A	A, A-7	Thread Take Up Lever Ass'y(A-Type)	실체기(조) 110-35003	(1)	
B-28	08-102A-123B	B, B-7	Thread Take Up Lever Ass'y (B-Type)	실체기(조)	(1)	B-27(A-TYPE)
B-29	08-102A-146L	BL, BL-7	Thread Take Up Lever Ass'y (B-Type:Option)	실체기 DB130 G222	1조	B-28(BL-TYPE)
B-30	SC-0504-1230		Screw(1/4" n=40)	실체기 핀 고정나사(1/4" n=40)	2	
B-35	SC-0507-1230		Screw(15/64" n=28)	상축 봇싱 고정나사(15/64" n=28)	1	
B-36	08-005R-250A		Oil Protection Rubber	오일막이 고무	1	
B-37	08-106C-2500		Protection Plate For B-7,8	링크캠 접촉판	1	
B-39	04-101A-250A	A, A-7	Needle Bar(A-TYPE)	바늘대(A形)	1	
B-40	04-101A-250B	B, B-7	Needle Bar(B-TYPE)	바늘대(B形)	1	
B-41	04-108A-2350		Needle Bar Bushing(U)	바늘대 상봇싱(235)	1	
B-42	04-103A-257A		Needle Bar Bushing(L)	바늘대 하봇싱(PBB)	1	
B-44	04-004C-2500		Thread Guide For B-42,43	바늘대 하봇싱 실안내	1	
B-45	04-005A-2500		Needle Bar Guide Slider Block	바늘대 안내 블록	1	
B-46	04-106C-250A	A, A-7	Needle Bar Thread Guide(A-TYPE)	바늘대 실안내(A形)	1	
B-47	04-001A-2700	B, B-7	Needle Bar Thread Guide(B-TYPE)	바늘대 실걸이	1	
B-48	SC-A131-4522		Screw(1/8" n=44)	홈볼이 납작 작은나사(1/8" n=44)	1	
B-49		A, A-7	Needle	바늘	1	
B-50		B, B-7	Needle	바늘	1	
B-51	13-0000-SE55		Synchronizer Ass'y Servo-3	싱크로나이저(Servo-3)	1조	
B-51-1	11-020A-2500		Magnetic Holder	마그네틱 홀더	(2)	B-51
B-51-2	11-022W-2500		Washer For B-51-1	마그네틱 홀더 씌와셔	(2)	
B-51-3	11-021S-2500		Screw For B-51-1	마그네틱 홀더 씌나사	(2)	
B-51-4	11-023A-2500		Synchronizer	싱크로나이저(내장형)	(1조)	
B-51-5	11-024S-2500		Screw For B-51-4	싱크로나이저 씌나사	(2)	
B-52	SC-A129-4515		Screw(1/4" n=40)	상축 카라 나사(1/4" n=40)	1	
B-54	02-018W-1230		Rubber For B-2	상축 유량 조절 고무	1	

NOTE:

A-7=KM-250A-7S
 B-7=KM-250B-7S
 A=KM-250A
 B=KM-250B

=Common Part



Upright Shaft & Lower Shaft Mechanism

세운축 및 하축관계

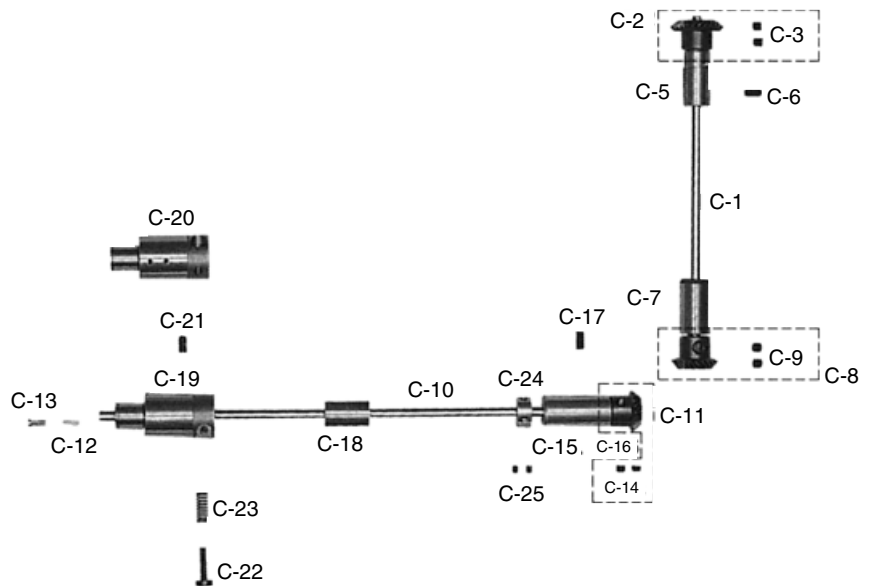
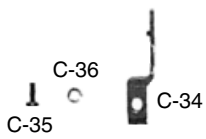
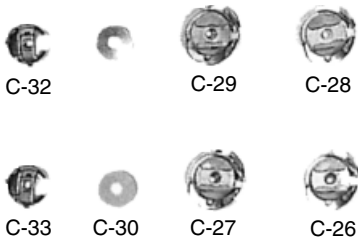

Ref. No.	Parts No.	Note	Name of Parts	품 명	Q' ty	Assembly No.
C-1	03-101A-1600		Upright Shaft	입축	1	
C-2	02-212A-1230		Upright Shaft Gear(U)	입축 상 기어	1	
C-3	SC-A129-4515		Screw(1/4" n = 40)	홈볼이 멈춤나사(1/4" n = 40)	2	
C-5	03-102A-1230		Upright Shaft Bushing(U)	입축 상붓싱	1	
C-6	SC-0507-1230		Screw(15/64" n = 28)	상축 붓싱 고정나사(15/64" n = 28)	1	
C-7	03-103A-1230		Upright Shaft Bushing(L)	입축 하붓싱	1	
C-8	02-213A-1230		Upright Shaft Gear(L)	입축 하기어	1	
C-9	SC-0129-7400		Screw(1/4" n = 40)	기어나사(1/4" n = 40)	2	
C-10	07-103A-250A		Lower Shaft	하축	1	
C-11	02-214A-1230		Lower Shaft Gear	하축기어	1	
C-12	07-005M-1230	A, A-7	Lower Shaft Felter	하축 헬트	1	
C-13	07-004S-1230		Cap Screw For Lower Shaft oil	하축 헬트 꽃이 나사	1	
C-14	SC-A129-4515		Screw(1/4" n = 40)	홈볼이 멈춤나사(1/4" n = 40)	2	
C-16	07-102A-1600		Lower Shaft Bushing(R)	하축 뒷붓싱	1	
C-17	SC-0507-1230		Screw(1/4" n = 40)	상축 붓싱 고정나사(1/4" n = 40)	1	
C-18	07-103A-1600		Lower Shaft Bushing(M)	하축 중붓싱(7.94×20×25)	1	
C-19	07-107A-257A	A-7, B-7	Lower Shaft Bushing(F)	하축 전붓싱	1	
C-20	07-107A-250A	A, B	Lower Shaft Bushing(F)	하축 전붓싱	1	
C-21	SC-0114-1230		Screw(15/64" n = 28)	실체기 힌지핀 나사(15/64" n = 28)	1	
C-22	SC-0361-1230		Screw(3/16" n = 32)	하축 오일 조절나사(3/16" n = 32)	1	
C-23	07-015G-1230		Spring For C-22	하축 오일 조절나사 스프링	1	
C-24	44-025A-1230		Collar For Lower Shaft	오일 펌프 카라(B) 7.94×17×8	1	
C-25	SC-0104-5607		Screw(11/64" n = 40)	하축 중 베어리 붓싱 고정나사(11/64" n = 40)	2	
C-26	07-003A-270A	A-7	Rotary Hook Ass'y	가마(HSH-7.94BTR)	1조	
C-27	07-007A-123A	A	Rotary Hook Ass'y	가마(HSH-7.94B)	1조	
C-28	07-003A-270B	B-7	Rotary Hook Ass'y	가마(HSH-7.94BOHNTR)	1조	
C-29	07-007A-123B	B	Rotary Hook Ass'y	가마(HSH-7.94BOH)	1조	
C-30	07-105A-2700		Bobbin(AL)	보빈	1	
C-32	07-104A-2700	A-7, B-7	Bobbin Case Ass'y	보빈케이스	1조	
C-33	07-106A-123A	A, B	Bobbin Case Ass'y	보빈케이스	1조	
C-34	07-013A-1230		Inner Bobbin Stopper	가마잡이	1	
C-35	SC-A174-4122		Screw(11/64" n = 40)	홈볼이 납작 작은나사(11/64" n = 40)	1	
C-36	07-011W-1230		Washer For C-35	가마잡이 와셔	1	

NOTE:

A-7=KM-250A-7S
 B-7=KM-250B-7S
 A=KM-250A
 B=KM-250B
=Common Part

수정 리스트

Changed Parts List

No.	Ref. No.	Parts No.	Name of Parts	Contents	Date	Old Parts No.	Remarks
1	B-54	02-018W-1230	Washer For B-2	Substitution	99.12	02-118W-1230	
2	D-98-1	06-048B-2507	Reverse Feed Solenoid Ass'y	Additional Parts	00.3		00. 1/4
3	D-87	06-023G-257A	Spring for D-112	Substitution	00.3	06-023G-7400	
4	P-12-1	07-001A-146L	Roraty Hook Ass'y	Additional Parts	00.6		250BL
5	P-13-1	07-008A-146L	Bobbin	Additional Parts	00.6		250BL
6	P-14-1	07-006A-146L	Bobbin Case	Additional Parts	00.6		250BL
7	O-10	10-010A-25BL	Thread Trimming Holder	Substitution	00.10	01-010A-64L7	00. 3/4
8	P-11-1	07-010A-2BLS	Lower Shaft Bushing(F)	Only for Trimming M/C	00.10	07-010A-25BL	00. 4/4
9	D-27	06-119S-1230	Screw(3/16" n=28)	Substitution	01.01	SC-0497-4122	00. 4/4
10	D-53	06-119S-1230	Screw(3/16" n=28)	Substitution	01.01	SC-0497-4122	00. 4/4
11	D-62	06-119S-1230	Screw(3/16" n=28)	Substitution	01.01	SC-0497-4122	00. 4/4
12	C-5	03-102A-1230	Upright Shaft Bushing(U)	Substitution	01.01	03-002A-1230	00. 4/4
13	D-13	06-105A-2350	Feed Connecting Link(A)	Substitution	01.01	06-005A-2350	00. 4/4
14	D-14	06-106A-2350	Feed Connecting Link(B)	Substitution	01.01	06-006A-2350	00. 4/4
15	D-70	06-119A-1370	Feed Regulating	Substitution	01.01	06-019A-1370	00. 4/4
16	D-69	06-119A-2350	Feed Regulating	Substitution	01.01	06-019A-2350	00. 4/4
17	D-48	06-117A-1230	Feed Bar Block and Shaft	Substitution	01.01	06-017A-1230	00. 4/4
18	B-41	04-108A-2350	Needle Bar Upper Bushing	Substitution	01.01	04-008A-2350	00. 4/4
19	D-51	06-128A-2350	Feed Lifting Bell Arm	Substitution	01.01	06-028A-2350	00. 4/4
20	B-18	02-211A-1230	Main Shaft Gear	Substitution	01.01	02-111A-1230	00. 4/4
21	C-2	02-212A-1230	Upright Shaft Upper Gear	Substitution	01.01	02-112A-1230	00. 4/4
22	C-8	02-213A-1230	Upright Shaft Lower Gear	Substitution	01.01	02-113A-1230	00. 4/4
23	C-11	02-214A-1230	Lower Shaft Gear	Substitution	01.01	02-114A-1230	00. 4/4
24	A-4-1	01-001A-25BL	Arm. Bed	Additional Parts	01.02		00. 4/4
25	A-4-2	01-001A-25LS	Arm. Bed	Additional Parts	01.02		00. 4/4
26	J-19	01-213R-1230	Hinge Rubber(S)	Change of Blue Point	01.03	01-013R-1230	01. 1/4
27	J-18	01-214R-1230	Hinge Rubber(M)	Change of Blue Point	01.03	01-014R-1230	01. 1/4
28	A-7	SC-0523-1230	Screw(3/16" n=28)	Substitution	01.10	SC-0523-4122	01. 4/4
29	A-9	SC-0548-7400	Screw(3/16" n=28)	Substitution	01.10	SC-0548-4122	01. 4/4
30	A-14	SC-0523-1230	Screw(3/16" n=28)	Substitution	01.10	SC-0523-4122	01. 4/4
31	A-22	SC-0346-2350	Screw(M8×1.25)	Substitution	01.10	SC-0346-4113	01. 4/4
32	A-24	SN-0112-1230	Nut(M8×1.25)	Substitution	01.10	SN-0122-4000	01. 4/4
33	A-48	SC-0542-1230	Screw(11/64" n=40)	Substitution	01.10	SC-0542-4515	01. 4/4
34	A-52	SC-0120-1230	Screw(9/64" n=40)	Substitution	01.10	SC-0120-2118	01. 4/4
35	A-54	SC-0120-1230	Screw(9/64" n=40)	Substitution	01.10	SC-012302118	01. 4/4
36	A-57	SC-0114-1230	Screw(15/64" n=28)	Substitution	01.10	SC-0114-4515	01. 4/4
37	A-59	01-127A-1230	Thread Guide with Three Holes	Substitution	01.10	01-027A-1230	01. 4/4
38	B-1	02-101A-2500	Upper Shaft	Substitution	01.10	02-001A-2500	01. 4/4
39	B-2	02-115C-2500	Oil Adjusting Pin for B-1	Substitution	01.10	02-015C-2500	01. 4/4
40	B-7	02-102A-250A	Link Cam (A-Type)	Substitution	01.10	02-002A-250A	01. 4/4

NOTE)

수정 리스트 Changed Parts List

No.	Ref. No.	Parts No.	Name of Parts	Contents	Date	Old Parts No.	Remarks
41	B-8	02-102A-250B	Link Cam (B-Type)	Substitution	01.10	02-002A-250B	01. 1/4
42	B-9	SC-0123-1230	Screw(9/32" n = 28)	Substitution	01.10	SC-0123-4422	01. 4/4
43	B-12	02-104A-250A	Upper Shaft Bushing(F)	Substitution	01.10	02-004A-250A	01. 4/4
44	B-14	02-105A-2500	Upper Shaft Bushing(M)	Substitution	01.10	02-005A-2500	01. 4/4
45	B-15	SC-0114-1230	Screw(15/64" n = 28)	Substitution	01.10	SC-0114-4515	01. 4/4
46	B-16	02-121A-1230	Upper Shaft Collar	Substitution	01.10	02-021A-1230	01. 4/4
47	B-21	02-106A-257B	Upper Shaft Bushing(R)	Substitution	01.10	02-006A-257B	01. 4/4
48	B-25	SC-0150-2500	Screw(15/64" n = 28)	Substitution	01.10	SC-0150-4122	01. 4/4
49	B-26	SC-0188-1230	Screw(5/16" n = 24)	Substitution	01.10	SC-0188-4124	01. 4/4
50	B-30	SC-0504-1230	Screw(1/4" n = 40)	Substitution	01.10	SC-A129-4515	01. 4/4
51	B-35	SC-0507-1230	Screw(15/64" n = 28)	Substitution	01.10	SC-0507-4515	01. 4/4
52	B-42	04-103A-257A	Needle Bar Bushing(U)	Substitution	01.10	04-003A-257A	01. 4/4
53	B-52	SC-A129-1230	Screw(1/4" n = 40)	Substitution	01.10	SC-0504-4515	01. 4/4
54	C-1	03-101A-1600	Upright Shaft	Substitution	01.10	03-001A-1600	01. 4/4
55	C-6	SC-0507-1230	Screw(15/64" n = 28)	Substitution	01.10	SC-0507-4515	01. 4/4
56	C-7	03-103A-1230	Upright Shaft Bushing(U)	Substitution	01.10	03-003A-1600	01. 4/4
57	C-9	SC-0129-7400	Screw(1/4" n = 40)	Substitution	01.10	SC-0129-4515	01. 4/4
58	C-16	07-110A-1230	Lower Shaft Bushing(R)	Substitution	01.10	07-010A-1230	01. 4/4
59	C-17	SC-0507-1230	Screw(1/4" n = 40)	Substitution	01.10	SC-0507-4515	01. 4/4
60	C-18	07-103A-1600	Lower Shaft Bushing(M)	Substitution	01.10	07-003A-1600	01. 4/4
61	C-19	07-107A-257A	Lower Shaft Bushing(F)	Substitution	01.10	07-007A-257A	01. 1/4
62	C-21	SC-0114-1230	Screw(15/64" n = 28)	Substitution	01.10	SC-0114-4515	01. 4/4
63	C-22	SC-0361-1230	Screw (3/16" n = 32)	Substitution	01.10	SC-0361-4122	01. 4/4
64	C-25	SC-0104-5607	Screw(11/64" n = 40)	Substitution	01.10	SC-0104-4517	01. 4/4
65	C-30	07-105A-2700	Bobbin(AL)	Substitution	01.10	07-005A-2700	01. 4/4
66	C-10	07-103A-2500	Lower Shaft	Substitution	01.10	07-003A-2500	01. 4/4
67	C-31	07-105A-2700	Bobbin(Steel)	Substitution	01.10	07-008A-1230	01. 4/4
68	D-1	06-101A-250A	Feed Cam A	Substitution	01.10	06-001A-250A	01. 4/4
69	D-2	SC-0129-7400	Screw(1/4" n = 40)	Substitution	01.10	SC-0129-4515	01. 4/4
70	D-5	06-102A-2500	Feed Cam C	Substitution	01.10	06-002A-2500	01. 4/4
71	D-6	S-0504-1230	Screw(1/4" n = 40)	Substitution	01.10	SC-0504-4515	01. 4/4
72	D-7	06-103A-2500	Feed Rocker Shaft Connecting Rod	Substitution	01.10	06-003A-2500	01. 4/4
73	D-8	06-154A-1230	Crank Rod	Substitution	01.10	06-003A-2350	01. 4/4
74	D-9	06-104A-257A	Feed Regulator Link	Substitution	01.10	06-004A-257A	01. 4/4
75	D-11	06-104P-2350	Feed Connection Link Pin(A)	Substitution	01.10	06-004P-2350	01. 4/4
76	D-12	SC-0496-3710	Screw(11/64" n = 40)	Substitution	01.10	SC-0496-4122	01. 4/4
77	D-15	06-107P-2350	Feed Adjusting Link Hinge Pin(A)	Substitution	01.10	06-007P-2350	01. 4/4
78	D-16	SC-0504-1230	Screw(1/4" n = 40)	Substitution	01.10	SC-0504-4515	01. 4/4
79	D-17	06-108P-2350	Feed Adjusting Link Hinge Pin(B)	Substitution	01.10	06-008P-2350	01. 4/4
80	D-18	SC-0504-1230	Screw(1/4" n = 40)	Substitution	01.10	SC-0504-4515	01. 4/4

NOTE)

수정 리스트

Changed Parts List

No.	Ref. No.	Parts No.	Name of Parts	Contents	Date	Old Parts No.	Remarks
81	D-19	06-109P-2350	Feed Connection Link Pin(B)	Substitution	01.10	06-009P-2350	01. 1/4
82	D-20	SC-0496-3710	Screw(11/64" n = 40)	Substitution	01.10	SC-0496-4122	01. 4/4
83	D-21	06-110P-2350	Feed Connection Link Pin(C)	Substitution	01.10	06-010P-2350	01. 4/4
84	D-22	SC-0175-1230	Screw(11/64" n = 40)	Substitution	01.10	SC-0175-4522	01. 4/4
85	D-25	SC-0175-1230	Screw(11/64" n = 40)	Substitution	01.10	SC-0175-4522	01. 4/4
86	D-26	06-311A-2350	Level Feed Crank(R)	Substitution	01.10	06-011A-2350	01. 4/4
87	D-28	06-112A-2350	Feed Rock Shaft	Substitution	01.10	06-012A-2350	01. 4/4
88	D-31	SC-0114-1230	Screw(15/64" n = 28)	Substitution	01.10	SC-0114-4515	01. 4/4
89	D-32	06-113A-2350	Feed Rock Shaft Bushing(F)	Substitution	01.10	06-013A-2350	01. 4/4
90	D-33	SC-0114-1230	Screw(15/64" n = 28)	Substitution	01.10	SC-0114-4515	01. 4/4
91	D-36	SC-0307-1230	Screw(3/16" n = 32)	Substitution	01.10	SC-0307-4122	01. 4/4
92	D-37	06-114A-2350	Feed Bar Shaft	Substitution	01.10	06-014A-2350	01. 4/4
93	D-40	SC-0133-1230	Screw(1/8" n = 44)	Substitution	01.10	SC-0133-4122	01. 4/4
94	D-42	SC-0122-1230	Screw(15/64" n = 28)	Substitution	01.10	SC-0122-4522	01. 4/4
95	D-47	SC-0130-1230	Screw(1/8" n = 44)	Substitution	01.10	SC-0130-4122	01. 4/4
96	D-54	06-116A-2350	Feed Lifting Shaft	Substitution	01.10	06-016A-2350	01. 4/4
97	D-56	06-139A-1230	Feed Lifting Shaft Bushing(F)	Substitution	01.10	06-039A-1230	01. 4/4
98	D-57	SC-0114-1230	Screw(15/64" n = 28)	Substitution	01.10	SC-0114-4515	01. 4/4
99	D-58	06-140A-1230	Feed Lifting Shaft Bushing(R)	Substitution	01.10	06-040A-1230	01. 4/4
100	D-59	SC-0114-1230	Screw(15/64" n = 28)	Substitution	01.10	SC-0114-4515	01. 4/4
101	D-64	SC-0175-1230	Screw(11/64" n = 40)	Substitution	01.10	S-0175-4522	01. 1/4
102	D-66	05-118A-2350	Feed Regulator Shaft	Substitution	01.10	06-018A-2350	01. 4/4
103	D-68	SC-0507-1230	Screw(15/64" n = 28)	Substitution	01.10	SC-0507-4515	01. 4/4
104	D-71	SC-A174-4122	Screw(11/64" n = 40)	Substitution	01.10	SC-0174-4122	01. 4/4
105	D-72	06-220A-2350	Collar for D-66	Substitution	01.10	06-020A-2350	01. 4/4
106	D-73	SC-0129-7400	Screw(1/4" n = 40)	Substitution	01.10	S-0129-4515	01. 4/4
107	D-74	06-221A-2350	Feed Adjusting Shaft	Substitution	01.10	06-021A-2350	01. 4/4
108	D-75	06-122A-2350	Connecting Rod for Feed Regulator	Substitution	01.10	06-022A-2500	01. 4/4
109	D-78	SC-0528-1230	Screw(9/64" n = 40)	Substitution	01.10	SC-0528-4125	01. 4/4
110	D-81	06-125A-2500	Reverse Feed Control Lever Shaft	Substitution	01.10	06-025A-2500	01. 4/4
111	D-85	SC-0184-1600	Screw(3/16" n = 28)	Substitution	01.10	SC-0184-4118	01. 4/4
112	D-86	SC-0174-1230	Screw(11/64" n = 40)	Substitution	01.10	SC-0174-4122	01. 4/4
113	D-90	SN-0101-1600	Screw(11/64" n = 40)	Substitution	01.10	SN-0101-4000	01. 4/4
114	D-95	SC-0193-1230	Screw(3/16" n = 28)	Substitution	01.10	SC-0193-4122	01. 4/4
115	D-100	SC-0166-2350	Screw(M5×0.8)	Substitution	01.10	SC-0166-4119	01. 4/4
116	D-102	SC-0108-2350	Screw(M6)	Substitution	01.10	SC-0109-4113	01. 4/4
117	D-109	SC-0175-2350	Screw(11/64" n = 40)	Substitution	01.10	SC-0175-4522	01. 4/4
118	D-113	SC-0186-1230	Screw(3/16" n = 32)	Substitution	01.10	SC-0186-4118	01. 4/4
119	D-114	SC-0185-1230	Screw(3/16" n = 32)	Substitution	01.10	SC-0185-4124	01. 4/4
120	D-3	06-101A-250B	Feed Cam B	Substitution	01.10	06-001A64L7	01. 4/4

NOTE)

수정 리스트

Changed Parts List

No.	Ref. No.	Parts No.	Name of Parts	Contents	Date	Old Parts No.	Remarks
121	D-10	06-103A-2350	Feed Regulator Link	Substitution	01.10	10-010A-64L7	01. 1/4
122	D-75-1	06-122A-1370	Feed Regulator Rod	Substitution	01.10	06-022A-1370	01. 4/4
123	E-1	10-101A-2700	Fixed Mes	Substitution	01.10	10-001A-2700	01. 4/4
124	E-3	SC-0137-2700	Screw(1/8" n = 40)	Substitution	01.10	SC-0137-4222	01. 4/4
125	E-4	SN-0103-2700	Nut(1/8" n = 40)	Substitution	01.10	SN-0103-4000	01. 4/4
126	E-6	SC-0543-2302	Screw(11/64" n = 40)	Substitution	01.10	SC-0543-4525	01. 4/4
127	E-17	SN-0101-1600	Nut(11/64" n = 40)	Substitution	01.10	SN-0101-4000	01. 4/4
128	E-19	SC-0108-2350	Screw(M6)	Substitution	01.10	SC-0108-4113	01. 4/4
129	E-28	SN-0115-7400	Nut(3/16" n = 32)	Substitution	01.10	SN-0115-4000	01. 4/4
130	E-33	SN-0105-3400	Nut(15/64" n = 28)	Substitution	01.10	SN-0105-4000	01. 4/4
131	E-37	SC-0548-7400	Screw(3/16" n = 28)	Substitution	01.10	SC-0548-4122	01. 4/4
132	E-45	SN-0115-7400	Nut(3/16" n = 32)	Substitution	01.10	SN-0115-4000	01. 4/4
133	E-47	SC-0548-7400	Screw(3/16" n = 28)	Substitution	01.10	SC-0548-4122	01. 4/4
134	E-50	SC-0496-3710	Screw(11/64" n = 40)	Substitution	01.10	SC-0496-4122	01. 4/4
135	E-55	SC-0183-2700	Screw(15/64" n = 28)	Substitution	01.10	SC-0183-4122	01. 4/4
136	F-1	SC-0339-1230	Screw(9/16" n = 20)	Substitution	01.10	SC-0339-4125	01. 4/4
137	F-6	05-101A-1230	Presser Bar	Substitution	01.10	05-001A-1230	01. 4/4
138	F-7	05-115A-2500	Presser Bar Bushing	Substitution	01.10	05-015A-2500	01. 4/4
139	F-8	05-103A-1370	Presser Bar Holder	Substitution	01.10	05-003A-1370	01. 4/4
140	F-9	SC-0498-3710	Screw(11/64" n = 40)	Substitution	01.10	SC-0498-4122	01. 4/4
141	F-13	SC-0157-1230	Screw(9/64" n = 40)	Substitution	01.10	SC-0157-2118	01. 1/4
142	F-15	SC-0502-2302	Screw(9/64" n = 40)	Substitution	01.10	SC-0502-4125	01. 4/4
143	F-18	SC-0528-1230	Screw(9/64" n = 40)	Substitution	01.10	SC-0528-4125	01. 4/4
144	F-38	SC-0516-3500	Screw(3/16" n = 28)	Substitution	01.10	SC-0516-4119	01. 4/4
145	F-39	SC-0175-1230	Screw(11/64" n = 40)	Substitution	01.10	SC-0175-4522	01. 4/4
146	F-44	SC-0548-7400	Screw(3/16" n = 28)	Substitution	01.10	SC-0548-4122	01. 4/4
147	F-46	SC-0175-1230	Screw(11/64" n = 40)	Substitution	01.10	SC-0175-4522	01. 4/4
148	G-2	SC-0548-7400	Wiper Bracket Ass'y	Substitution	01.10	SC-0548-4122	01. 4/4
149	G-7	SC-0120-1230	Screw(9/64" n = 40)	Substitution	01.10	SC-0120-2118	01. 4/4
150	G-9	SC-0105-7500	Screw(M4)	Substitution	01.10	SC-0105-4517	01. 4/4
151	G-11	SN-0101-1600	Nut(11/64" n = 40)	Substitution	01.10	SN-0101-4000	01. 4/4
152	G-14	SN-0101-1600	Nut(11/64" n = 40)	Substitution	01.10	SN-0101-4000	01. 4/4
153	G-18	SN-0101-1600	Nut(3/16" n = 32)	Substitution	01.10	SN-0101-4000	01. 4/4
154	G-21	SN-0101-1600	Nut(11/64" n = 40)	Substitution	01.10	SN-0101-4000	01. 4/4
155	G-24	SC-0548-7400	Screw(3/16" n = 28)	Substitution	01.10	SC-0548-4122	01. 4/4
156	G-26	SC-0120-1230	Screw(9/64" n = 40)	Substitution	01.10	SC-0120-2118	01. 4/4
157	G-28	SC-0196-2700	Screw(M3×0.5)	Substitution	01.10	SC-0196-4118	01. 4/4
158	H-2	SC-0523-1230	Screw(9/64" n = 40)	Substitution	01.10	SC-0523-4122	01. 4/4
159	H-8	SC-0178-7400	Screw(11/64" n = 40)	Substitution	01.10	SC-0178-4118	01. 4/4
160	I-7	SC-0120-1230	Screw(9/64" n = 40)	Substitution	01.10	SC-0120-2118	01. 4/4

NOTE)

수정 리스트

Changed Parts List

No.	Ref. No.	Parts No.	Name of Parts	Contents	Date	Old Parts No.	Remarks
161	I-11	SC-0548-7400	Screw(3/16" n = 28)	Substitution	01.10	SC-0548-4122	01. 1/4
162	I-14-3	SC-0528-1230	Screw(9/64" n = 40)	Substitution	01.10	SC-0528-4125	01. 4/4
163	I-14-14	SC-0120-1230	Screw(9/64" n = 40)	Substitution	01.10	SC-0120-2118	01. 4/4
164	I-14-15	44-119A-1230	Collar for Impeller Shaft	Substitution	01.10	44-019A-1230	01. 4/4
165	I-14-16	SC-0512-1230	Screw(11/64" n = 40)	Substitution	01.10	SC-0512-4515	01. 4/4
166	I-16	SC-0548-7400	Screw(3/16" n = 28)	Substitution	01.10	SC-0548-4122	01. 4/4
167	I-18	44-115A-1230	Oil Pump Connection Spring	Substitution	01.10	44-015A-1230	01. 4/4
168	I-19	SC-0542-1230	Screw(11/64" n = 40)	Substitution	01.10	SC-0542-4515	01. 4/4
169	J-25	SC-0344-8260	Screw(5/16" n = 24)	Substitution	01.10	SC-0344-4125	01. 4/4
170	J-33	SC-0347-1230	Screw(M8×1.25)	Substitution	01.10	SC-0347-4122	01. 4/4
171	J-36	SC-0509-1230	Screw(15/64" n = 28)	Substitution	01.10	SC-0509-4515	01. 4/4
172	J-37-7	SC-0181-1230	Screw(5/16" n = 18)	Substitution	01.10	SC-0181-4116	01. 4/4
173	J-41	SC-0106-7400	Screw(15/64" n = 28)	Substitution	01.10	SC-0106-4111	01. 4/4
174	J-42	SC-0545-1230	Screw(15/64" n = 28)	Substitution	01.10	SC-0545-4518	01. 4/4
175	J-43	SC-0546-1230	Screw(15/64" n = 28)	Substitution	01.10	SC-0546-4518	01. 4/4
176	J-44	SN-0105-3400	Nut(15/64" n = 28)	Substitution	01.10	SN-0105-4000	01. 4/4
177	K-6	SC-0548-7400	Screw(3/16" n = 28)	Substitution	01.10	SC-0548-4122	01. 4/4
178	K-7-6	SC-0183-2700	Screw(15/64" n = 28)	Substitution	01.10	SC-0183-4122	01. 4/4
179	K-7-8	SN-0121-7400	Nut(15/64" n = 28)	Substitution	01.10	SN-0121-4000	01. 4/4
180	K-7-10	SC-0497-1230	Screw(3/16" n = 28)	Substitution	01.10	SC-0497-4122	01. 4/4
181	K-8-5	SC-0512-1230	Screw(11/64" n = 40)	Substitution	01.10	SC-0512-4515	01. 1/4
182	M-7-26	SC-0108-2350	Screw(M6)	Substitution	01.10	SC-0108-4113	01. 4/4
183	J-8	07-105A-2700	Bobbin(Steel)	Substitution	01.10	07-008A-1230	01. 4/4
184	O-2	SC-A301-4119	Screw(9/64" n = 40)	Substitution	01.10	SC-0145-4114	01. 4/4
185	O-15	SN-0115-7400	Nut for O-14	Substitution	01.10	SN-0115-4000	01. 4/4
186	O-17	SC-0109-2350	Screw	Substitution	01.10	SC-0109-4113	01. 4/4
187	O-24	SN-0115-7400	Nut(3/16" n = 32)	Substitution	01.10	SN-011S-4000	01. 4/4
188	O-26	SC-0169-1600	Screw(15/64" n = 28)	Substitution	01.10	SC-0169-4122	01. 4/4
189	O-29	SC-0317-2700	Screw(15/64" n = 28)	Substitution	01.10	SC-0317-4517	01. 4/4
190	O-3	SC-0137-2700	Screw(1/8" n = 40)	Substitution	01.10	SC-0137-4222	01. 4/4
191	O-30	06-220A-2350	Collar for O-18	Substitution	01.10	06-020A-2350	01. 4/4
192	O-31	SC-A308-4517	Screw(1/4" n = 40)	Substitution	01.10	SC-0308-4517	01. 4/4
193	O-33	SC-0190-2700	Screw(3/16" n = 32)	Substitution	01.10	SC-0190-4111	01. 4/4
194	O-4	SN-0103-2700	Nut(1/8" n = 40)	Substitution	01.10	SN-0103-4000	01. 4/4
195	O-41	SN-0105-3400	Nut(15/64" n = 28)	Substitution	01.10	SN-0105-4000	01. 4/4
196	O-44	SC-0190-2700	Screw(M5×P0.8)	Substitution	01.10	SC-0485-4113	01. 4/4
197	O-45	07-011W-1230	Spring Washer for O-44	Substitution	01.10	SW-0120-1011	01. 4/4
198	O-46	10-020W-2700	Washer for O-44	Substitution	01.10	SC-0164-4517	01. 4/4
199	O-48	SC-0164-2700	Screw(M5×P0.8)	Substitution	01.10	10-050A-25BL	01. 4/4
200	O-49	10-144A-2507	Thread Trimming Solenoid Ass'y	Substitution	01.10	10-050A-25BL	01. 4/4

NOTE)

수정 리스트

Changed Parts List

No.	Ref. No.	Parts No.	Name of Parts	Contents	Date	Old Parts No.	Remarks
201	O-5	10-005A-64L7	Thread Retaining Plate	Substitution	01.10	10-055A-64L7	01. 1/4
202	O-52	SC-0109-2350	Screw(M6×P1)	Substitution	01.10	SC-0109-4113	01. 4/4
203	O-6	SC-0543-2302	Screw(11/64" n = 40)	Substitution	01.10	SC-017S-4522	01. 4/4
204	O-9	SC-A154-4114	Screw(11/64" n = 40)	Substitution	01.10	SC-0154-4114	01. 4/4
205	P-22	SC-0543-2302	Screw	Substitution	01.10	SC-0543-4525	01. 4/4
206	P-24	SC-0211-7500	Screw	Substitution	01.10	SC-0328-4113	01. 4/4
207	P-5	02-109A-25BL	Link Cam	Substitution	01.10	02-009A-25BL	01. 4/4
208	P-6	03-101A-1230	Upright Shaft	Substitution	01.10	03-001A-1230	01. 4/4
209	P-11	07-110A-25BL	Lower Shaft Bushing(F)	Substitution	01.10	07-010A-25BL	01. 4/4
210	P-11-1	07-110A-2BLS	Lower Shaft Bushing(F)	Substitution	01.10	07-010A-2BLS	01. 4/4
211	P-12-1	07-007A-146L	Rotary Hook Ass'y	Substitution	01.10	07-001A-146L	01. 4/4
212	P-13	07-125A-64L7	Bobbin	Substitution	01.10	07-025A-64L7	01. 4/4
213	P-13-1	07-108A-146L	Bobbin	Substitution	01.10	07-008A-146L	01. 4/4
214	A-4-2	01-001A-2BLS	Arm Bed	Substitution	02.03	01-001A-25LS	02. 1/4
215	A-13	01-241M-2500	Gasket For A-5	Substitution	02.03	01-041M-2500	02. 1/4
216	A-33	01-135A-123B	Needle Plate(B-Type)	Substitution	02.03	01-035A-123B	02. 1/4
217	A-49		Three Hole Thread Guide	Deleted Parts	02.03	01-015A-1230	02. 1/4
218	A-50		Nut For A-49	Deleted Parts	02.03	01-027C-1230	02. 1/4
219	B-27	08-201A-250A	Thread Take Up Lever Ass'y(A-Type)	Additional Parts	02.03	08-001A-250A	02. 1/4
220	B-28	08-102A-123B	Thread Take Up Lever Ass'y(B-Type)	Additional Parts	02.03	08-002A-123B	02. 1/4
221	B-29	08-102A-146L	Thread Take Up Lever Ass'y(B-Type: Option)	Substitution	02.03	08-002A-146L	02. 1/4
222	B-51	11-0000-2507	Synchronizer Ass'y	Substitution	02.03	12-0000-2507	02. 1/4
223	B-52	SC-A129-4515	Screw(1/4" n = 40)	Substitution	02.03	SC-A129-1230	02. 1/4
224	C-10	07-103A-250A	Lower Shaft	Substitution	02.03	07-103A-2500	02. 1/4
225	C-10-1		Lower Shaft	Deleted Parts	02.03	07-003A-257A	02. 1/4
226	C-31		Bobbin(Steel)	Deleted Parts	02.03	07-105A-2700	02. 1/4
227	D-119	06-027P-2350	Dial Pin	Additional Parts	02.03		02. 1/4
228	D-120	06-028C-257A	Thread Regulator Control Plate(INSERT)	Additional Parts	02.03		02. 1/4
229	D-121	06-028C-257B	Thread Regulator Control Plate(INSERT)	Additional Parts	02.03		02. 1/4
230	E-42	SN-0105-3400	Nut(15/64" n = 28)	Substitution	02.03	SN-0105-4000	02. 1/4
231	E-45	SB-0115-3400	Nut(3/16" n = 32)	Substitution	02.03	SN-0115-4000	02. 1/4
232	J-8		Bobbin(Steel)	Deleted Parts	02.03	07-105A-2700	02. 1/4
233	J-11	10-101A-2700	Fixed Mes	Substitution	02.03	10-001A-2700	02. 1/4
234	K-6		Screw(3/16" n = 28)	Deleted Parts	02.03	SC-0548-7400	02. 1/4
235	K-7-16		Spring for K-8-1	Deleted Parts	02.03	43-019G-257A	02. 1/4
236	K-8-3		E-Ring(φ 6)	Deleted Parts	02.03	40-002C-2350	02. 1/4
237	K-8-6	SC-0548-7400	Screw	Additional Parts	02.03		02. 1/4
238	O-8	10-106A-64L7	Rotary Mes	Substitution	02.03	10-008A-64L7	02. 1/4
239	O-10	10-110A-25BL	Thread Trimming Holder	Substitution	02.03	10-010A-25BL	02. 1/4
240	O-16	10-116A-64L7	Thread Trimming Lever	Substitution	02.03	10-016A-64L7	02. 1/4

NOTE)

수정 리스트

Changed Parts List

No.	Ref. No.	Parts No.	Name of Parts	Contents	Date	Old Parts No.	Remarks
241	O-18	10-118A-64L7	Thread Trimming Shaft	Substitution	02.03	10-018A-64L7	02. 1/4
242	O-21	10-123A-64L7	Side Arm	Substitution	02.03	10-023A-64L7	02. 1/4
243	O-25	10-127A-64L7	Cam Follower Crank	Substitution	02.03	10-027A-64L7	02. 1/4
244	P-13	07-225A-64L7	Bobbin	Substitution	02.03	07-125A-64L7	02. 1/4
245	P-13-1		Bobbin	Deleted Parts	02.03	07-108A-146L	02. 1/4
246	A-8	01-139C-2500	Thread Take Up Cover	Substitution	02.6	01-039C-2500	02. 2/4
247	A-12	01-140C-2500	Back Cover	Substitution	02.6	01-040C-2500	02. 2/4
248	A-21	01-115C-1230	Bed base(R)	Substitution	02.6	01-015C-1230	02. 2/4
249	A-26	01-142A-257A	Code Holder "A"	Substitution	02.6	01-042A-257A	02. 2/4
250	A-27	01-143A-257A	Code Holder "B"	Substitution	02.6	01-043A-257A	02. 2/4
251	A-47	40-201A-2700	Sub Upper Thread Tension Control Ass'y	Substitution	02.6	40-001A-2700	02. 2/4
252	B-37	08-106C-2500	Protention Plate for D-7.8	Substitution	02.6	08-006C-2500	02. 2/4
253	B-46	04-106C-250A	Needle Bar Thread Guide(A-TYPE)	Substitution	02.6	04-006C-250A	02. 2/4
254	C-20	07-107A-250A	Lower Shaft Bushing(F)	Substitution	02.6	07-007A-250A	02. 2/4
255	D-43	06-215A-2350	Feed Bar	Substitution	02.6	06-015A-2350	02. 2/4
256	D-99	06-130A-257A	Bracket for Reverse Feed Solenoid	Substitution	02.6	06-030A-257A	02. 2/4
257	D-120	06-028C-257A	Feed Regulator Control Plate(INSERT)	Substitution	02.6	06-028C-257M	02. 2/4
258	D-122	06-103A-25BL	Feed Regulator Link	Additional Part	02.6		02. 2/4
259	D-123	06-103A-2BLS	Feed Regulator Link	Additional Part	02.6		02. 2/4
260	E-15	10-112A-257A	Thread Trimming Lever Connecting Link	Substitution	02.6	10-012A-257A	02. 2/4
261	E-21	10-116W-257A	Washer for E-20	Substitution	02.6	10-016W-257A	02. 2/4
262	E-34	10-122P-257A	Stopper Pin	Substitution	02.6	10-022P-257A	02. 2/4
263	E-36	10-124C-257A	Spring Holder	Substitution	02.6	10-024C-257A	02. 2/4
264	E-38	10-125A-257A	Thread Trimming Cam	Substitution	02.6	10-025A-257A	02. 2/4
265	E-40	10-126A-257A	Clutch Lever Ass'y	Substitution	02.6	10-026A-257A	02. 2/4
266	E-48	10-130A-257A	Solenoid Connection Link	Substitution	02.6	10-030A-257A	02. 2/4
267	E-49	10-131P-257A	Solenoid Pin	Substitution	02.6	10-031P-257A	02. 2/4
268	E-58	01-114C-2350	Bobbin Catcher Holder	Substitution	02.6	01-014C-2350	02. 2/4
269	E-64	01-105A-2350	Bed Hase "FRONT"(B)	Substitution	02.6	01-005A-2350	02. 2/4
270	F-19	43-102A-2500	Presser Lifter Cam Shaft	Substitution	02.6	43-002A-2500	02. 2/4
271	F-21	43-103A-2500	Presser Lifter Link	Substitution	02.6	43-003A-2500	02. 2/4
272	F-24	43-105A-2500	Presser Lifter Lever	Substitution	02.6	43-005A-2500	02. 2/4
273	F-25	43-106C-2500	Presser Lifter Connection Bar	Substitution	02.6	43-006C-2500	02. 2/4
274	F-27	43-108A-2500	Knee Lifting Link	Substitution	02.6	43-008A-2500	02. 2/4
275	F-29	43-109C-2500	Knee Lifting bar	Substitution	02.6	43-009C-2500	02. 2/4
276	F-32	40-105C-2500	Tension Release Plate	Substitution	02.6	40-005C-2500	02. 2/4
277	F-37	40-109A-257A	Tension Release Cable Holder(U)	Substitution	02.6	40-009A-257A	02. 2/4
278	F-45	40-110A-257A	Tension Release Cable Holder(L)	Substitution	02.6	40-010A-257A	02. 2/4
279	G-3	11-102A-257A	Wiper Bracket Ass'y	Substitution	02.6	11-002A-257A	02. 2/4
280	G-8	11-106A-257A	Wiper Crank Ass'y	Substitution	02.6	11-006A-257A	02. 2/4

NOTE)

수정 리스트

Changed Parts List

No.	Ref. No.	Parts No.	Name of Parts	Contents	Date	Old Parts No.	Remarks
281	G-23	11-112A-257A	Wiper Base	Substitution	02.6	11-012A-257A	02. 2/4
282	H-5	12-104P-5607	Reverse Button Actuator Pin	Substitution	02.6	12-004P-5607	02. 2/4
283	H-7	12-101A-257A	Reverse Feed Control Lever	Substitution	02.6	12-001A-257A	02. 2/4
284	I-4	44-120A-1600	Arm Oil Shield	Substitution	02.6	44-020A-1600	02. 2/4
285	I-5	44-131C-1230	Arm Oil Shield	Deleted Parts	02.6	44-031C-1230	02. 2/4
286	I-10	44-117A-1600	Oil Return Tube Holder	Substitution	02.6	44-017A-1600	02. 2/4
287	I-14-11	44-104C-2350	Cover for Oil Pump	Substitution	02.6	44-004C-2350	02. 2/4
288	I-14-13	44-105C-2350	Magnetic Holder	Substitution	02.6	44-005C-2350	02. 2/4
289	I-14-14	44-120S-1230	Screw(9/64" n = 40)	Substitution	02.6	SC-0120-1230	02. 2/4
290	J-9	91-105C-2700	Spanner	Substitution	02.6	91-005C-2700	02. 2/4
291	L-1	01-135A-235A	Needle Plate (AU-TYPE)	Substitution	02.6	01-035A-235A	02. 2/4
292	L-5	08-101A-257U	Thread Take-Up Lever Ass'y	Substitution	02.6	08-001A-257U	02. 2/4
293	L-15	05-115C-257U	Arm Thread Guide Holder Plates	Substitution	02.6	05-015C-257U	02. 2/4
294	L-16	05-116W-257U	Washer for Arm Thread Guide	Substitution	02.6	05-016W-257U	02. 2/4
295	N-5	08-101A-25BH	Thread Take-Up Lever Ass'y	Substitution	02.6	08-001A-25BH	02. 2/4
296	N-7	06-315A-2350	Feed Bar(BH-TYPE)	Additional Parts	02.6		02. 2/4
297	O-50	10-151A-25BL	Base for O-49	Substitution	02.6	10-051A-25BL	02. 2/4
298	P-8	06-190A-25BL	Bracket for Reverse Feed Solenoid	Substitution	02.6	06-090A-25BL	02. 2/4
299	P-14-1	07-106A-146L	Bobbin Case Assembly	Substitution	02.6	07-006A-146L	02. 2/4
300	P-15	08-102A-146L	Thread Take Up Lever Assembly	Substitution	02.6	08-002A-146L	02. 2/4
301	E-8	10-106A-2700	Rotary Mes	Change of Blue Point	03.04	10-002A-257A	03. 2/4
302	J-18	01-241R-1230	Head Support Rubber "A"	Substitution	03.04	01-214R-1230	03. 2/4
303	I-14-6	44-126A-1230	Impeller	Substitution	03.03	44-026A-1230	03. 1/4
304	A-6	01-137M-2500	Gasket For A-5	Substitution	03.06	01-037M-2500	03. 2/4
305	A-13	01-141M-2500	Gasket For A-12	Substitution	03.06	01-241M-2500	03. 2/4
306	A-13-1	01-142M-2500	Gasket For A-12	Substitution	03.06	01-241M-2500	03. 2/4
307	C-16	07-102A-1600	Lower Shaft Bushing(R)	Substitution	03.06	07-110A-1230	03. 2/4
308	B-23	02-207A-257A	Pulley(Only For Trimming M/C)	Substitution	03.06	02-007A-257A	03. 2/4
309	A-14	SC-0548-7400	Screw(3/16" n = 28)	Substitution	03.06	SC-0523-1230	03. 2/4
310	J-2	91-102C-1230	Driver(Large)	Substitution	03.06	91-002C-1230	03. 2/4
311	J-3	91-103C-1230	Driver(Middle, Small)	Substitution	03.06	91-003C-1230	03. 2/4
312	A-14	SC-0548-7400	Screw(3/16" n = 28)	Substitution	04.01	SC-0548-7400	04. 1/15
313	A-14-1	SC-0523-1230	Screw(3/16" n = 28)	Substitution	04.01		04. 1/15
314	A-14-2	SC-0548-7400	Screw(3/16" n = 28)	Substitution	04.01		04. 1/15
315	A-14-3	SC-0215-1230	Screw(9/64" n = 40)	Substitution	04.01		04. 1/15
316	A-14-4	02-019W-1230	Washer	Substitution	04.01		04. 1/15
317	A-16	01-003R-1600	Arm Rubber Cap(S)	Substitution	04.01	04-104R-1230	04. 1/15
318	A-31	01-135A-123A	Needle Plate(A-TYPE)	Substitution	04.01	01-035A-120A	04. 1/15
319	A-32	01-135A-123B	Needle Plate(B-TYPE)	Substitution	04.01	01-035A-120B	04. 1/15
320	A-34	01-136S-1230	Screw(11/64" n = 40)	Substitution	04.01	SC-A119-4119	04. 1/15

NOTE)

수정 리스트

Changed Parts List

No.	Ref. No.	Parts No.	Name of Parts	Contents	Date	Old Parts No.	Remarks
321	A-35	01-434A-1230	Slide Plate	Substitution	04.01	01-034A-1230	04. 1/15
322	A-37	01-136S-1230	Screw(11/64" n = 40)	Substitution	04.01	SC-A119-4119	04. 1/15
323	A-45	01-116A-2350	Upper Thread Guide Pin and Nut	Substitution	04.01	01-016A-2350	04. 1/15
324	A-59	01-027A-1230	Thread Guide With Three Holes	Substitution	04.01	01-127A-1230	04. 1/15
325	B-23-1	02-207A-257A	Pulley(Only For Regular M/C)	Substitution	04.01	02-007A-2500	04. 1/15
326	B-29	08-102A-146L	Thread Take Up Lever Ass'y(B-Type)	Substitution	04.01		04. 1/15
327	B-39	04-101A-250A	Needle Bar(A-Type)	Substitution	04.01	04-001A-250A	04. 1/15
328	B-40	04-101A-250B	Needle Bar(B-Type)	Substitution	04.01	04-001A-250B	04. 1/15
329	B-51	13-0000-SE55	Synchronizer Ass'y Servo-3	Substitution	04.01	11-0000-2507	04. 1/15
330	C-16	07-102A-1600	Lower Shaft Bushing(R)	Substitution	04.01	07-102A-257A	04. 1/15
331	C-32	07-104A-2700	Bobbin Case Ass'y	Substitution	04.01	07-004A-2700	04. 1/15
332	C-33	07-106A123A	Bobbin Case Ass'y	Substitution	04.01	07-006A-123A	04. 1/15
333	D-27	06-119S-1230	Screw(3/16" n = 28)	Substitution	04.01		04. 1/15
334	D-30	06-140A-1230	Feed Rock Shaft Bushing(F)	Substitution	04.01	06-040A-1230	04. 1/15
335	D-41	06-102W-2350	Washer For D-37	Substitution	04.01	06-002W-2350	04. 1/15
336	D-44	06-107A-123A	Feed Dog(A-Type)	Substitution	04.01	06-007A-123A	04. 1/15
337	D-45	06-107A-123B	Feed Dog(B-Type)	Substitution	04.01	06-007A-123B	04. 1/15
338	D-46	06-007A-235B	Feed Dog(BH-Type)	Substitution	04.01		04. 1/15
339	D-50	06-020S-1230	Screw(3/16" n = 32)	Substitution	04.01		04. 1/15
340	D-53	06-119S-1230	Screw(3/16" n = 28)	Substitution	04.01		04. 1/15
341	D-62	06-119S-1230	Screw(3/16" n = 28)	Substitution	04.01		04. 1/15
342	D-65	01-037R-1230	Rubber Cap For D-28.54(F)	Substitution	04.01		04. 1/15
343	D-67	06-043R-1230	O-Ring For D-66	Substitution	04.01		04. 1/15
344	D-78	SC-0528-1230	Screw(9/64" n = 40)	Substitution	04.01		04. 1/15
345	D-87	06-023G-257A	Spring For D-112	Substitution	04.01		04. 1/15
346	D-87-1	06-023G-257B	Spring For D-112	Substitution	04.01		04. 1/15
347	D-92	10-042C-2700	O-Ring For D-91	Substitution	04.01	06-010R-1230	04. 1/15
348	D-96	06-026P-1230	Pin For D-93.94	Substitution	04.01	06-029P-1230	04. 1/15
349	D-103	06-131A-257A	Reverse Feed Solenoid Crank	Substitution	04.01	06-031A-257A	04. 1/15
350	E-1	SC-A301-4119	Screw(9/64" n = 40)	Substitution	04.01	10-101A-2700	04. 1/15
351	E-2	10-201A-2700	Fixde Mes	Substitution	04.01	SC-A301-4119	04. 1/15
352	E-8	10-106A-2700	Rotary Mes	Substitution	04.01		04. 1/15
353	E-9	10-106A-235B	Rotary Mes	Substitution	04.01	10-006A-235B	04. 1/15
354	E-11	10-108A-257A	Thread Trimming Holder	Substitution	04.01	10-008A-257A	04. 1/15
355	E-13	10-110W-2700	Washer For E-11	Substitution	04.01	10-010W-2700	04. 1/15
356	E-18	10-114A-257A	Thread Trimming Lever	Substitution	04.01	10-014A-257A	04. 1/15
357	E-20	10-115A-257A	Thread Trimming Shaft	Substitution	04.01	10-015A-257A	04. 1/15
358	E-25	10-119A-257A	Slide Arm	Substitution	04.01	10-019A-257A	04. 1/15
359	E-30	10-121A-257A	Cam Follower Crank	Substitution	04.01	10-021A-257A	04. 1/15
360	E-45	SN-0115-7400	Nut(3/16" n = 32)	Substitution	04.01	SN-0115-3400	04. 1/15

NOTE)

수정 리스트

Changed Parts List

No.	Ref. No.	Parts No.	Name of Parts	Contents	Date	Old Parts No.	Remarks
361	E-47	SC-0548-7400	Screw(3/16" n=28)	Substitution	04.01	SV-0548-4122	04. 1/15
362	E-65	SC-0508-1230	Screw	Substitution	04.01		04. 1/15
363	F-45	40-211A-257A	Tension Release Cable Holder(L)(#5)	Substitution	04.01	40-110A-257A	04. 1/15
364	F-47	40-210A-257A	Tension Release Cable Holder	Substitution	04.01		04. 1/15
365	J-7	07-105A-2700	Bobbin(AL)	Substitution	04.01	07-005A-2700	04. 1/15
366	J-11	10-201A-2700	Fixed Mes	Substitution	04.01	10-101A-2700	04. 1/15
367	J-12	91-106C-2700	Head Cover	Substitution	04.01	91-006C-2700	04. 1/15
368	J-49	01-135A-123A	Needle Plate(A-Type)	Substitution	04.01	01-235A-250A	04. 1/15
369	J-50	01-135A-123B	Needle Plate(B-Type)	Substitution	04.01	01-035A-123B	04. 1/15
370	J-51	06-135A-235B	Needle Plate(BH-Type)	Substitution	04.01	06-035A-235B	04. 1/15
371	L-10	07-106A-123A	Bobbin Case Ass'y	Substitution	04.01	07-006A-123A	04. 1/15
372	L-12	06-107A-257U	Feed Dog(AU-Type)	Substitution	04.01	06-007A-257U	04. 1/15
373	M-4	02-101A-257N	Upper Shaft(NP-Type)	Substitution	04.01	02-001A-257N	04. 1/15
374	M-7-25	01-019P-2350	Guide Pin For Synchronizer	Substitution	04.01		04. 1/15
375	M-7-26	SC-0108-4113	Screw(M6)	Substitution	04.01		04. 1/15
376	M-7-27	01-020W-2350	Washer For Synchronizer	Substitution	04.01		04. 1/15
377	N-4	01-102A-250H	Link Cam(BH-Type)	Substitution	04.01	02-002A-250H	04. 1/15
378	O-1	10-101A-64L7	Fixed Mes	Substitution	04.01	10-001A-64L7	04. 1/15
379	O-32	10-118A-2700	Stopper	Substitution	04.01	10-018A-64L7	04. 1/15
380	O-42	43-004S-3400	Stud Cres For O-47	Substitution	04.01		04. 1/15
381	P-2	01-105A-2350	Bed Base "Front"(B)	Substitution	04.01	01-017C-1230	04. 1/15
382	P-3	01-242M-25BL	Modle Mark(KM-250BL-7S)	Substitution	04.01	01-042M-25BL	04. 1/15
383	P-4	01-139C-2500	Thread Take Up Cover	Substitution	04.01	01-009A-2350	04. 1/15
384	P-9	07-101A-25BL	Lower Shaft	Substitution	04.01	07-001A-25BL	04. 1/15
385	P-11	07-110A-25BL	Lower Shaft Bushing(F)	Substitution	04.01		04. 1/15
386	P-11-1	07-110A-2BLS	Lower Shaft Bushing(F)	Substitution	04.01		04. 1/15
387	P-12	07-024A-64L7	Rotary Hook Ass'y	Substitution	04.01		04. 1/15
388	P-14	07-026A-64L7	Bobbin Case Assembly	Substitution	04.01		04. 1/15
389	P-21	40-140C-64L7	Tension Release Cable Holder(L)	Substitution	04.01	40-040C-64L7	04. 1/15
390	P-23	40-142A-64L7	Bracket For P-21	Substitution	04.01	40-042A-64L7	04. 1/15

NOTE)

D

Feed Mechanism 피이드 관계

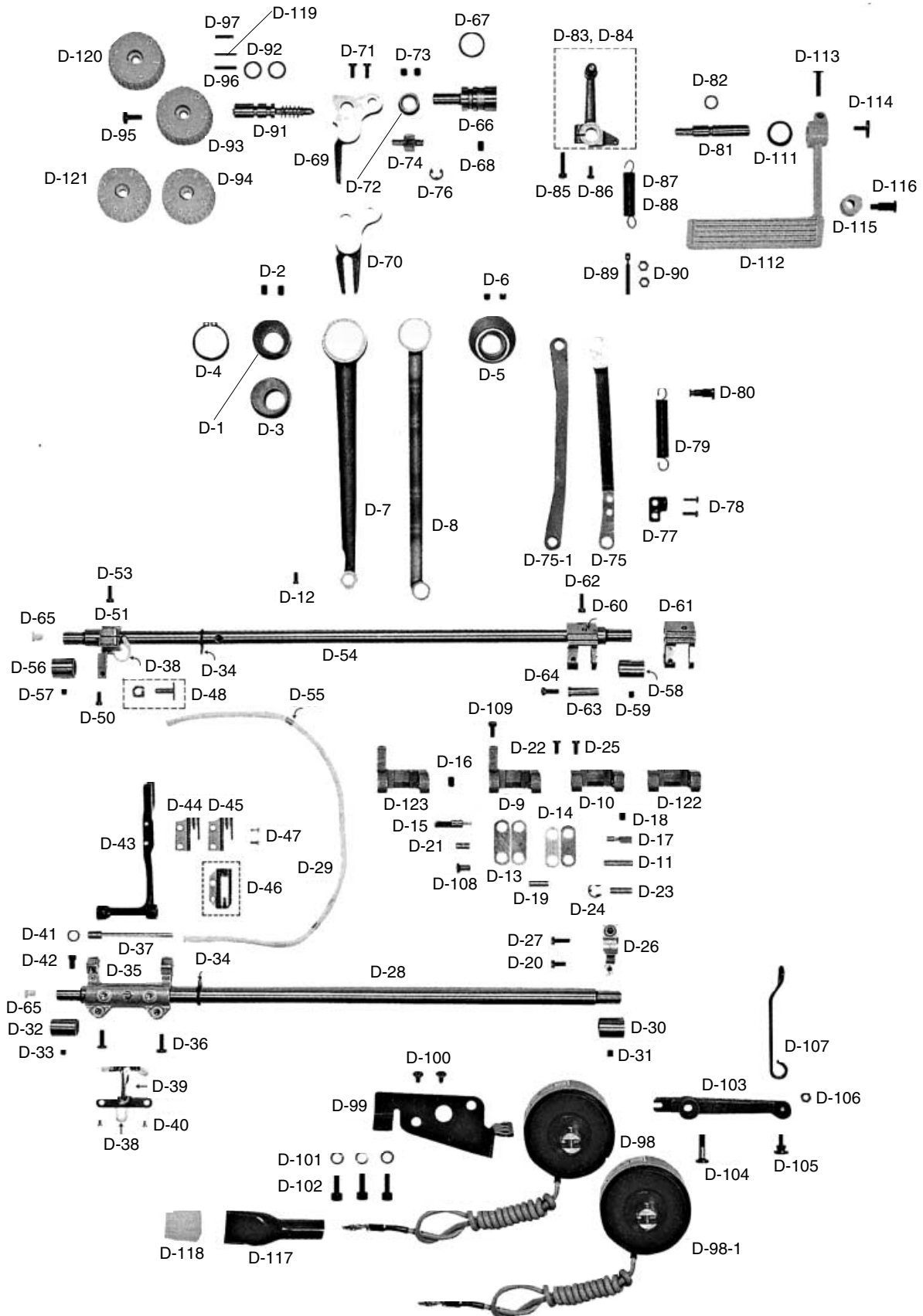

Ref. No.	Parts No.	Note	Name of Parts	품 명	Q' ty	Assembly No.
D-1	06-101A-250A	A, A-7	Feed Cam A	피이드 캠A	1	
D-2	SC-0129-7400		Screw(1/4" n=40)	기어 나사(1/4" n=40)	2	
D-3	06-101A-250B	B, B-7	Feed Cam B	피이드 캠B	1	
D-4	06-103C-235B		Stop-Ring "C" For D-1,3	스냅링 28#D	1	
D-5	06-102A-2500		Feed Cam C	피이드 캠 C	1	
D-6	SC-0504-1230		Screw(1/4" n=40)	실채기 핀 고정나사(1/4" n=40)	2	
D-7	06-103A-2500		Feed Rocker Shaft Connecting Rod	수평이송 로드	1	
D-8	06-154A-1230		Crank Rod	크랭크 로드	1	
D-9	06-104A-257A	A-7, B-7	Feed Regulator Link	피이드 조절 링크	1	
D-10	06-103A-2350	A, B	Feed Regulator Link	피이드 조절 링크	1	
D-11	06-104P-2350		Feed Connection Link Pin(A)	피이드 연결 링크핀(A)	1	
D-12	SC-0496-3710		Screw(11/64" n=40)	하축 뒷 붓싱 쥘나사(11/64" n=40)	1	
D-13	06-105A-2350		Feed Connection Link(A)	피이드 연결링크(A)	2	
D-14	06-106A-2350		Feed Connection Link(B)	피이드 연결링크(B)	2	
D-15	06-107P-2350		Feed Adjusting Link Hinge Pin(A)	피이드 조절링크 힌지핀(A)	1	
D-16	SC-0504-1230		Screw(1/4" n=40)	실채기 핀 고정나사(1/4" n=40)	1	
D-17	06-108P-2350		Feed Adjusting Link Hinge Pin(B)	피이드 조절 링크 힌지 핀(B)	1	
D-18	SC-0504-1230		Screw(1/4" n=40)	실채기 핀 고정나사(1/4" n=40)	1	
D-19	06-109P-2350		Feed Connection Link Pin(B)	피이드 연결 링크핀(B)	1	
D-20	SC-0496-3710		Screw(11/64" n=40)	하축 뒷 붓싱 쥘나사(11/64" n=40)	1	
D-21	06-110P-2350		Feed Connection Link Pin(C)	피이드 연결 링크핀(C)	1	
D-22	SC-0175-1230		Screw(11/64" n=40)	와이롯드 보강판 나사(11/64" n=40)	1	
D-23	06-023P-2350		Hinge Pin For D-75	피이드 조절 연결 로드 힌지핀	1	
D-24	04-009C-3710		E-Ring(φ5)	E링(φ5)	1	
D-25	SC-0175-1230		Screw(11/64" n=40)	와이롯드 보강판 나사(11/64" n=40)	1	
D-26	06-311A-2350		Level Feed Crank(R)	수평밀대 크랭크(後)	1	
D-27	06-119S-1230		Screw(3/16" n=28)	들대 고정나사(신)	1	
D-28	06-112A-2350		Feed Rock Shaft	수평밀대	1	
D-29	44-0000-1230		Oil Wick	오일심지	1	
D-30	06-140A-1230		Feed Rock Shaft Bushing(R)	들대붓싱(후) 11.11×16.8×20	1	
D-31	SC-0114-1230		Screw(15/64" n=28)	실채기 힌지핀 나사(15/64" n=28)	1	
D-32	06-113A-2350		Feed Rock Shaft Bushing(F)	수평밀대 前붓싱 11.11×17.74×16	1	
D-33	SC-0114-1230		Screw(15/64" n=28)	실채기 힌지핀 나사(15/64" n=28)	1	
D-34	06-021R-1230		Oil Cover For D-28,54	들밀대 고무마개	2	
D-35	06-008A-2350		Feed Bar Crank	톱니 받침 크랭크	1	
D-36	SC-0307-1230		Screw(3/16" n=32)	톱니 받침 크랭크 쥘나사(3/16" n=32)	2	
D-37	06-114A-2350		Feed bar Shaft	톱니 받침 축	1	
D-38	44-0000-1230		Oil Wick	오일심지	1	
D-39	44-009C-1230		Wick Holder For D-37	심지 지지대	1	
D-40	SC-0133-1230		Screw(1/8" n=44)	심지 지지대 나사(1/8" n=44)	2	
D-41	06-102W-2350		Washer For D-37	톱니 받침축 와셔	1	
D-42	SC-0122-1230		Screw(15/64" n=28)	톱니 받침축 고정나사(15/64" n=28)	1	
D-43	06-215A-2350		Feed Bar	톱니 받침	1	
D-44	06-107A-123A	A, A-7	Feed Dog(A-TYPE)	톱니(A形)	1	
D-45	06-107A-123B	B, B-7	Feed Dog(B-TYPE)	톱니(B形) P=2.1	1	
D-46	06-007A-235B		Feed Dog(BH-TYPE)(Magrin)	톱니(Magrin)	1	
D-47	SC-0130-1230		Screw(1/8" n=44)	톱니 쥘나사(1/8" n=44)	2	
D-48	06-117A-1230		Feed Bar Block and Shaft	톱니 받침 블록	1	
D-50	06-020S-1230		Screw(3/16" n=32)	톱니 받침B/L 고정나사	1	
D-51	06-128A-2350		Feed Lifting Shaft Crank(F)	들대 크랭크(前)	1	
D-53	06-119S-1230		Screw(3/16" n=28)	들대전 고정나사(신)	1	
D-54	06-116A-2350		Feed Lifting Shaft	들대	1	
D-55	44-029M-1230		Stopper For Wick	오일 심지 스톱퍼	2	
D-56	06-139A-1230		Feed Lifting Shaft Bushing(F)	들대 前 붓싱 11.11×17.46×20	1	
D-57	SC-0114-1230		Screw(15/64" n=28)	실채기 힌지핀 나사(15/64" n=28)	1	
D-58	06-140A-1230		Feed Lifting Shaft Bushing(R)	들대 後 붓싱 11.11×16.8×20	1	
D-59	SC-0114-1230		Screw(15/64" n=28)	실채기 힌지핀 나사(15/64" n=28)	1	
D-60	06-038A-235A	A, A-7	Feed Lifting Shaft Crank(R): A-TYPE	들대 크랭크(후)	1	
D-61	06-041A-235B	B, B-7	Feed Lifting Shaft Crank(R): B-TYPE	들대 크랭크(후)	1	
D-62	06-119S-1230		Screw(3/16" n=28)	들대전 고정나사(신)	1	
D-63	06-037P-1230		Crank Rod Connection Pin	들밀대 크랭크 핀	1	

NOTE:

A-7=KM-250A-7S
 B-7=KM-250B-7S
 A=KM-250A
 B=KM-250B
=Common Part

D

Feed Mechanism 피이드 관계

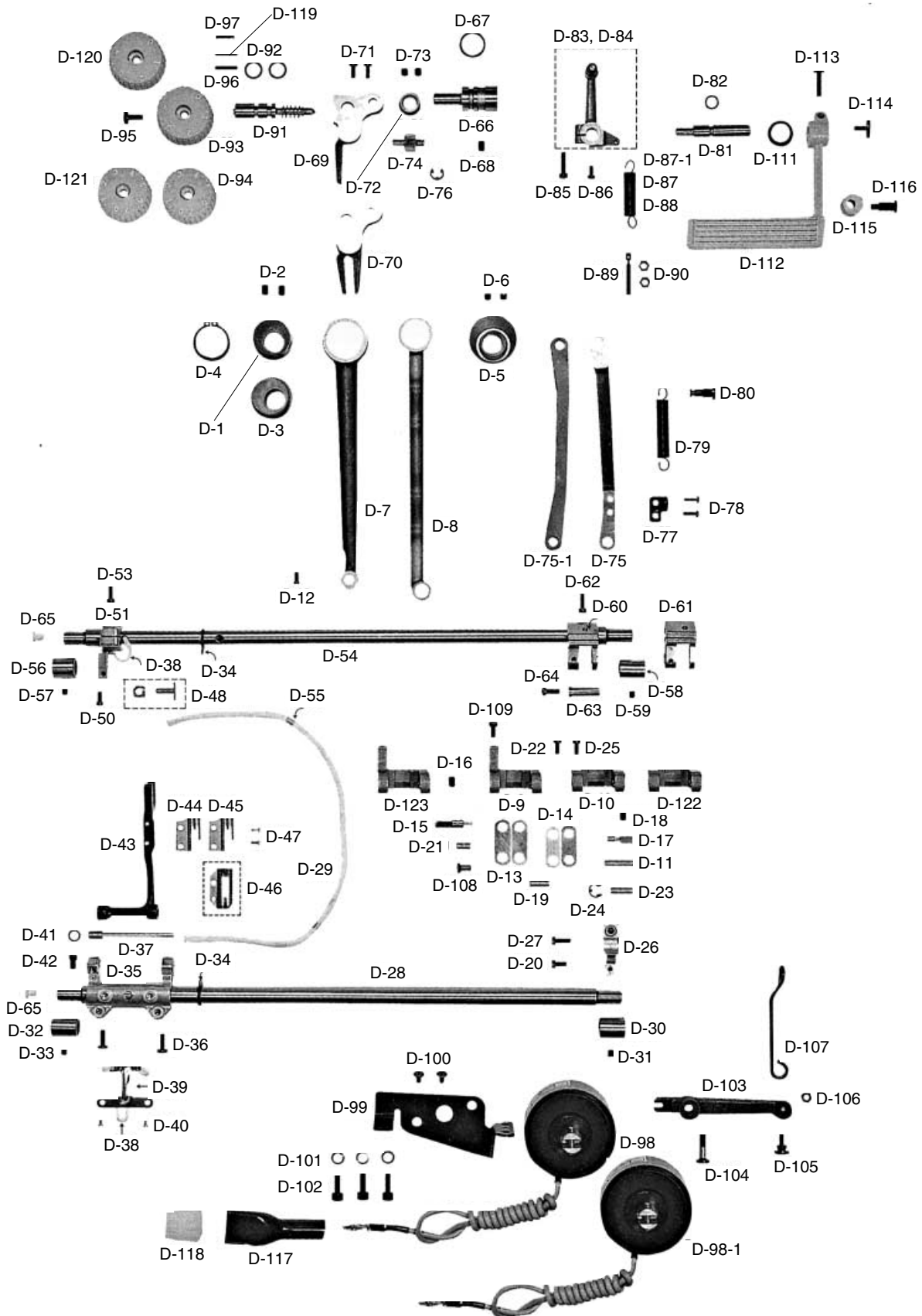

Ref. No.	Parts No.	Note	Name of Parts	품 명	Q' ty	Assembly No.
D-64	SC-0175-1230		Screw(11/64" n=40)	와이롯드 보강판 나사(11/64" n=40)	1	
D-65	01-037R-1230		Rubber Cap For D-28.54(F)	들밀대 유침마개	2	
D-66	06-118A-2350		Feed Regulator Shaft	피이드 조절기 축	1	
D-67	06-043R-1230		O-Ring For D-66	피이드 조절기 붓싱 오링	2	
D-68	SC-0507-1230		Screw(15/64" n=28)	상축 붓싱 고정나사(15/64" n=28)	1	
D-69	06-119A-2350	A-7, B-7	Feed Regulator	피이드 조절기	1	
D-70	06-119A-1370	A, B	Feed Regulator	피이드 조절기	1	
D-71	SC-A174-4122		Screw(11/64" n=40)	가마 잡이 나사(11/64" n=40)	2	
D-72	06-220A-2350		Collar For D-66	피이드 조절기 축 카라	1	
D-73	SC-0129-7400		Screw(1/4" n=40)	기어 나사(1/4" n=40)	2	
D-74	06-221A-2350		Feed Adjusting Shaft	피이드 조절축	1	
D-75	06-122A-2500	A-7, B-7	Connecting Rod For Feed Regulator	피이드 조절 로드	1	
D-75-1	06-122A-1370	A, B	Feed Regulator Rod	피이드 조절기 로드	1	
D-76	04-009C-3710		E-ring(φ5)	E링(φ5)	1	
D-77	06-023C-257A	A-7, B-7	B/T Spring Holder	자동 역진 스프링 홀더	1	
D-78	SC-0528-1230	A-7, B-7	Screw(9/64" n=40)	톱카바 나사(우)(9/64" n=40)	2	
D-79	06-023G-7400	A-7, B-7	Reverse Feed Spring	역진 레버 스프링	1	
D-80	06-024C-257A	A-7, B-7	Holder For D-79	자동 역진 스프링 걸이	1	
D-81	06-125A-2500		Reverse Feed Control Lever Shaft	역진 레버축	1	
D-82	06-042R-1230		O-Ring For D-81	레버축 오링	1	
D-83	06-026A-257A	A-7, B-7	Reverse Feed Lever Crank Ass'y	역진 레버 인장 크랭크(조)	(1)	
D-84	06-026A-250A	A, B	Reverse Feed Lever Crank Ass'y	역진 레버 인장 크랭크(조)	(1)	
D-85	SC-0184-1600		Screw(3/16" n=28)	수평 밀대 크랭크 쉘나사(3/16" n=28)	1	
D-86	SC-0174-1230		Screw(11/64" n=40)	가마잡이 나사(11/64" n=40)	1	
D-87	06-023G-257A	A-7	Spring For D-112	역진 레버 스프링	1	
D-87-1	06-023G-257B	B-7	Spring For D-112	역진 레버 스프링	1	
D-88	06-056G-2350	A, B	Spring For D-112	역진 레버 스프링	1	
D-89	06-040S-1600	A-7, B-7	Holder For D-112	스프링걸이 축나사	1	
D-90	SN-0101-1600	A-7, B-7	Nut(11/64" n=40)	스프링걸이 축나사 너트(11/64" n=40)	2	
D-91	06-027A-2500		Feed Regulator Dial Shaft	피이드 조절 다이알 축	1	
D-92	10-042C-2700		O-Ring For D-91	다이알 축 오링	2	
D-93	06-028C-250A	A	Feed Regulator Control Plate(4mm)	다이알 문자판(4mm)	1	
D-94	06-028C-250B	B	Feed Regulator Control Plate(7mm)	다이알 문자판(7mm)	1	
D-95	SC-0193-1230		Screw(3/16" n=28)	다이알판 고정나사(3/16" n=28)	1	
D-96	06-026P-1230	A, B	Pin For D-93.94	다이알 핀	1	
D-97	06-027G-1230		Spring For D-96	다이알 스프링	1	
D-98	06-048A-2507	B-7	Reverse Feed Solenoid Ass'y	역진 솔레노이드(SBT-5)	1조	
D-98-1	06-048B-2507	A-7	Reverse Feed Solenoid Ass'y	역진 솔레노이드(SBT-5)	1조	
D-99	06-130A-257A	A-7, B-7	Bracket For Reverse Feed Solenoid	역진 솔레노이드 브라켓	1	
D-100	SC-0166-2350	A-7, B-7	Screw(M5×0.8)	역진 솔레노이드 부착나사(M5×0.8)	2	
D-101	01-020W-2350	A-7, B-7	Spring Washer For Bracket	싱크로 베이스 스프링 와셔(φ6)	3	
D-102	SC-0108-2350	A-7, B-7	Screw(M6)	싱크로 베이스 고정볼트(M6)	3	
D-103	06-131A-257A	A-7, B-7	Reverse Feed Solenoid Crank	역진 솔레노이드 크랭크	1	
D-104	06-032S-257A	A-7, B-7	Stud Screw For D-103	역진 솔레노이드 크랭크 단나사	1	
D-105	06-033S-257A	A-7, B-7	Hinge Screw For D-107	역진 솔레노이드 연결로드 힌지나사	1	
D-106	40-005C-2700	A-7, B-7	Hinge Nut For D-107	케이블 연결너트(B)	1	
D-107	06-034A-257A	A-7, B-7	Reverse Solenoid Connecting Rod	역진 솔레노이드 연결로드	1	
D-108	06-035A-257A	A-7, B-7	Hinge Pin For D-107	역진 솔레노이드 연결로드 힌지핀	1	
D-109	SC-0175-1230	A-7, B-7	Screw(11/64" n=40)	와이롯드 보강판 나사(11/64" n=40)	1	
D-111	06-053W-1230		Washer For D-81	레버 와셔	1	
D-112	06-036C-2500		Feed Regulator Lever	역진 레버	1	
D-113	SC-0186-1230		Screw(3/16" n=32)	역진 레버 고정나사(3/16" n=32)	1	
D-114	SC-0185-1230		Screw(3/16" n=32)	레버 덮개 나사(3/16" n=32)	1	
D-115	06-072R-7507	A-7, B-7	Stopper Rubber For D-112	역진 레버 스톱퍼(상) 고무	1	
D-116	06-071S-7507	A-7, B-7	Stopper Stud Screw For D-112	역진 레버 스톱퍼(상) 단나사	1	
D-117	11-019M-2350	A-7, B-7	Terminal Tube(L)	솔레노이드 튜브	1	
D-118	11-018M-2350	A-7, B-7	Solenoid Terminal(12P)	솔레노이드 프리그	1	
D-119	06-027P-2350	A-7, B-7	Dial Pin	다이알 핀	1	
D-120	06-028C-257A	A-7	Feed Regulator ControlPlate(INSET)	다이알 문자판(4mm)(INSET)	1	
D-121	06-028C-257B	B-7	Feed Regulator ControlPlate(INSET)	다이알 문자판(7mm)(INSET)	1	
D-122	06-103A-25BL	BL	Feed Regulator Link	피드조절 링크(BL-TYPE)	1	
D-123	06-103A-2BLS	BL-7	Feed Regulator Link	피드조절 링크(BL-7 TYPE)	1	

NOTE:

A-7=KM-250A-7S
 B-7=KM-250B-7S
 A=KM-250A
 B=KM-250B
=Common Part

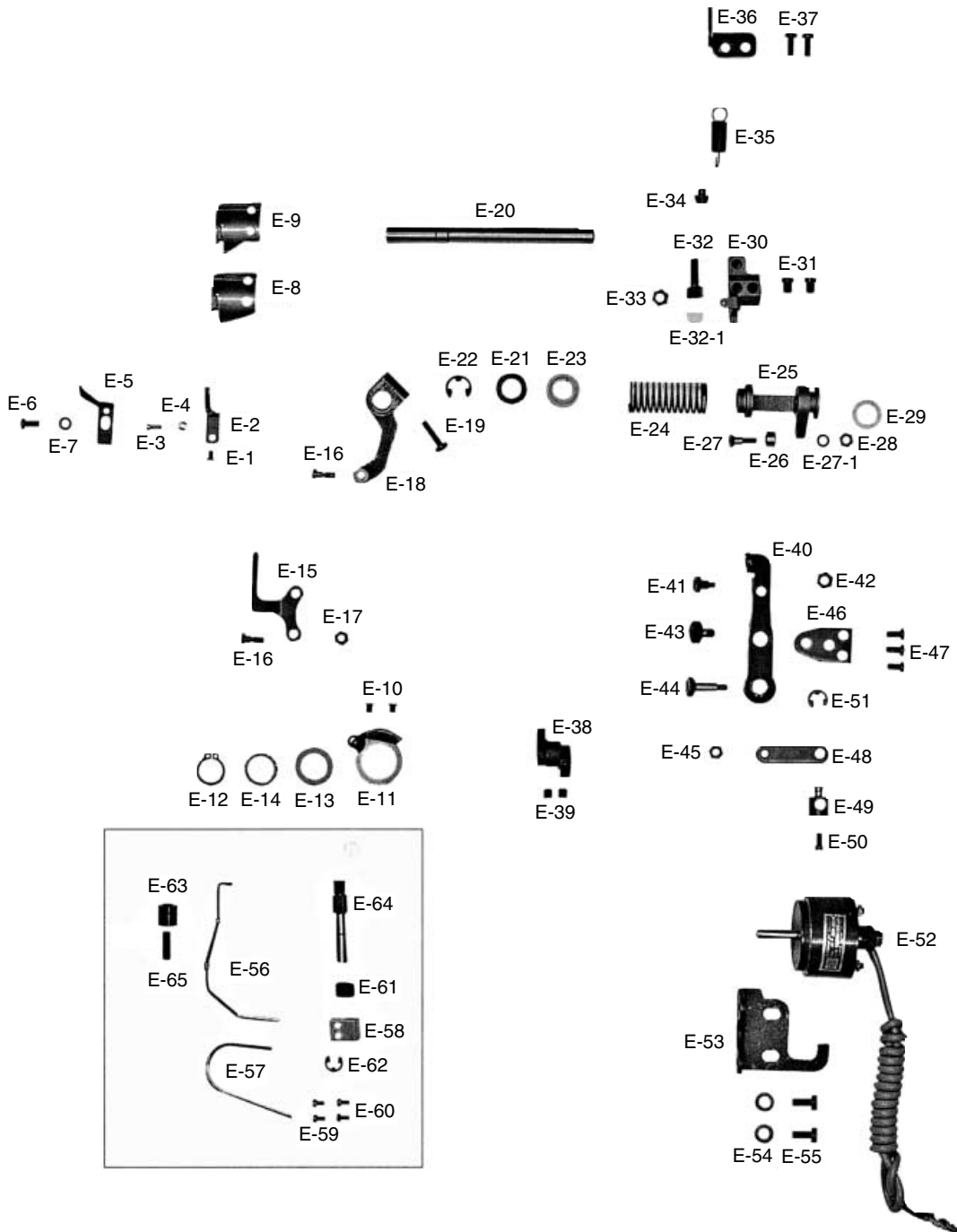

Ref. No.	Parts No.	Note	Name of Parts	품명	Q'ty	Assembly No.
E-1	SC-A301-4119	A-7, B-7	Screw(9/64" n=40)	홈볼이 절시 작은나사(9/64" n=40)	1	
E-2	10-201A-2700	A-7, B-7	Fixed Mes	고정메스(극진사용)	1	
E-3	SC-0137-2700	A-7, B-7	Screw(1/8" n=40)	고정메스 장력 조절나사(1/8" n=40)	1	
E-4	SN-0103-2700	A-7, B-7	Nut(1/8" n=40)	고정메스 장력 조절나사 너트(1/8" n=40)	1	
E-5	10-005A-2700	A-7, B-7	Thread Retaining Plate	실 가리개	1	
E-6	SC-0543-2302	A-7, B-7	Screw(11/64" n=40)	톱커버 힌지 고정나사(11/64" n=40)	1	
E-7	01-017W-1600	A-7, B-7	Washer For E-5	뒷뚜껑 씌워	1	
E-8	10-106A-2700	A-7	Rotary Mes	회전 메스	1	
E-9	10-106A-235B	B-7	Rotary mes	회전 메스	1	
E-10	SC-A154-4114	A-7, B-7	Screw(11/64" n=40)	접시머리 보울트(11/64" n=40)	2	
E-11	10-108A-257A	A-7, B-7	Thread Trimming Holder	사절홀더	1	
E-12	10-009C-2700	A-7, B-7	Stop-Ring For E-11	스냅링(15D)	1	
E-13	10-110W-2700	A-7, B-7	Washer For E-11	사절홀더 와셔	1	
E-14	10-011A-2700	A-7, B-7	Needle Bearing	니이들 베어링	1	
E-15	10-112A-257A	A-7, B-7	Thread Trimming Lever Connecting Link	사절레버 연결링크	1	
E-16	10-013S-257A	A-7, B-7	Stud Screw For E-15	사절레버 연결링크 단나사	2	
E-17	SN-0101-1600	A-7, B-7	Nut(11/64" n=40)	스프링 걸이 축나사 너트(11/64" n=40)	1	
E-18	10-114A-257A	A-7, B-7	Thread Trimming Lever	사절레버	1	
E-19	SC-0108-2350	A-7, B-7	Screw(M6)	싱크로 베이스 고정볼트(M6)	1	
E-20	10-115A-257A	A-7, B-7	Thread Trimming Shaft	사절축	1	
E-21	10-116W-257A	A-7, B-7	Washer For E-20	사절축 와셔	1	
E-22	43-009C-1600	A-7, B-7	E-Ring(φ9)	제어체 축링(E링 φ9)	1	
E-23	10-017A-257A	A-7, B-7	Return Spring Guide Bushing	리턴 스프링 가이드 붓싱	1	
E-24	10-018G-257A	A-7, B-7	Slide Arm Return Spring	슬라이드 아암 리턴 스프링	1	
E-25	10-119A-257A	A-7, B-7	Slide Arm	슬라이드 아암	1	
E-26	10-066A-7507	A-7, B-7	Roller	로울러	1	
E-27	10-067S-7507	A-7, B-7	Stud Screw For E-26	로울러 단나사	1	
E-27-1	07-011W-1230		Washer For E-27	가마잡이 와셔	1	
E-28	SN-0115-7400	A-7, B-7	Nut(3/16" n=32)	오프너 너트(3/16" n=32)	1	
E-29	10-044R-5607	A-7, B-7	Cushion Washer For E-20	쿠션 고무(B)	1	
E-30	10-121A-257A	A-7, B-7	Cam Follower Crank	사절캠 중동 크랭크	1	
E-31	15-002S-5607	A-7, B-7	Screw For E-30	노루발 상하운동 캠 고정나사	2	
E-32	10-032S-257A	A-7, B-7	Stopper Screw	스토퍼 쿠션 나사	1	
E-32-1	10-032R-257A	A-7, B-7	Cushion Rubber For E-32	스토퍼 쿠션 고무	1	
E-33	SN-0105-3400	A-7, B-7	Nut(15/64" n=28)	수평운동 롯데 단나사 너트(15/64" n=28)	1	
E-34	10-122P-257A	A-7, B-7	Stopper Pin	스토퍼 핀	1	
E-35	10-023G-257A	A-7, B-7	Spring For E-30	사절캠 중동 크랭크 스프링	1	
E-36	10-124C-257A	A-7, B-7	Spring Holder	스프링 걸이	1	
E-37	SC-0548-7400	A-7, B-7	Screw(3/16" n=28)	다이알 판 쥘나사(3/16" n=28)	2	
E-38	10-125A-257A	A-7, B-7	Thread Trimming Cam	사절캠	1	
E-39	SC-A308-4517	A-7, B-7	Screw(1/4" n=40)	육각구멍볼이 멈춤나사(1/4" n=40)	2	
E-40	10-126A-257A	A-7, B-7	Clutch Lever Ass'y	클러치 레버(組)	1조	
E-41	10-027S-257A	A-7, B-7	Stud Screw For E-40	클러치 레버 작동핀 나사	1	
E-42	SN-0105-3400	A-7, B-7	Nut(15/64" n=28)	육각너트(15/64" n=28)	1	
E-43	43-004S-3400	A-7, B-7	Clutch Lever Moving Pin Screw	무릎 올림봉 단나사	1	
E-44	10-028S-257A	A-7, B-7	Stud Screw For E-48	솔레노이드 연결 링크 단나사	1	
E-45	SN-0115-7400	A-7, B-7	Nut(3/16" n=32)	오프너 너트(3/16" n=32)	1	
E-46	10-029A-257A	A-7, B-7	Base Plate	베이스 플레이트	1	
E-47	SC-0548-7400	A-7, B-7	Screw(3/16" n=28)	홈볼이 납작 작은나사(3/16" n=28)	3	
E-48	10-130A-257A	A-7, B-7	Solenoid Connection Link	솔레노이드 연결링크	1	
E-49	10-131P-257A	A-7, B-7	Solenoid Pin	솔레노이드 핀	1	
E-50	SC-0496-3710	A-7, B-7	Screw(11/64" n=40)	하축 뒷 붓싱 고정나사(11/64" n=40)	1	
E-51	04-009C-3710	A-7, B-7	E-Ring(φ5)	E링(φ5)	1	
E-52	10-044A-2507	A-7, B-7	Thread Trimming Solenoid Ass'y	사절 솔레노이드(STT-5)	1조	
E-53	10-033A-257A	A-7, B-7	Base For E-52	사절 솔레노이드 베이스	1	
E-54	01-020W-2350	A-7, B-7	Washer For E-53	싱크로 베이스 스프링 와셔(φ6)	2	
E-55	SC-0183-2700	A-7, B-7	Screw(15/64" n=28)	베이스 고정나사B(15/64" n=28)	2	
E-56	01-012A-2350	A-7, B-7	Bobbin Catcher	보빈 압력봉	1	
E-57	50-001A-257A	A-7, B-7	Bobbin Catcher Lever	보빈 압력봉 레버	1	
E-58	01-114C-2350	A-7, B-7	Bobbin Catcher Holder	레버 잡이	1	
E-59	SC-A131-4522	A-7, B-7	Screw(1/8" n=44)	홈볼이 납작 작은나사(1/8" n=44)	2	
E-60	SC-A131-4522	A-7, B-7	Screw(1/8" n=44)	홈볼이 납작 작은나사(1/8" n=44)	2	
E-61	01-015C-2350	A-7, B-7	Bobbin Catcher Spring	보빈 압력 스프링	1	
E-62	06-020C-7400	A-7, B-7	E-Ring(φ6)	E링(φ6)	1	
E-63	01-016R-2700	A-7, B-7	Stopper Rubber For E-56	보빈 압력봉 스토퍼	1	
E-64	01-105A-2350	A-7, B-7	Bed base "FRONT"(B)	베드 받침(전)	1	
E-65	SC-0508-1230	A-7, B-7	Screw	풀리 고정나사	1	

NOTE:

A-7=KM-250A-7S
 B-7=KM-250B-7S
 A=KM-250A
 B=KM-250B
=Common Part

F

Presser Foot & Tension Release Mechanism 노루발 및 실 늦추기 관계

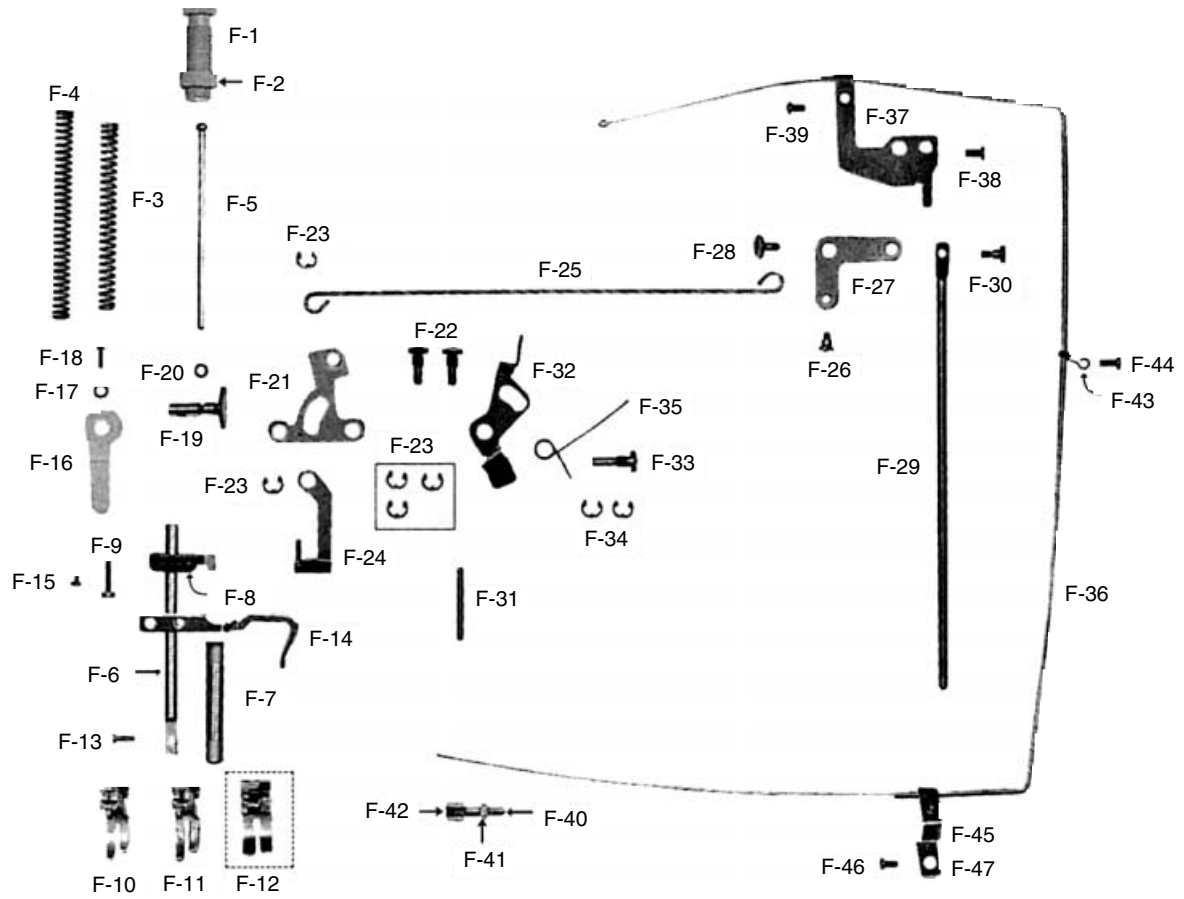

Ref. No.	Parts No.	Note	Name of Parts	품 명	Q' ty	Assembly No.
F-1	SC-0339-1230		Screw(9/16" n=20)	압력조절나사(9/16" n=20)	1	
F-2	05-002C-2500		Presser Adjusting Nut	압력 조절나사 너트	1	
F-3	05-014C-250A	A, A-7	Presser Adjusting Spring(A-TYPE)	압력 조절스프링(A形)	1	
F-4	05-014C-250B	B, B-7	Presser Adjusting Spring(B-TYPE)	압력 조절스프링(B形)	1	
F-5	05-007C-1230		Presser Adjusting Bar	압력 조절봉	1	
F-6	05-101A-1230		Presser Bar	누름대	1	
F-7	05-115A-2500		Presser Bar Bushing	누름대 붓싱	1	
F-8	05-103A-1370		Presser Bar Holder	누름대 잡이	1	
F-9	SC-0498-3710		Screw(11/64" n=40)	가마잡이 나사(11/64" n=40)	1	
F-10	05-005A-1600	A, A-7	Presser Foot Ass'y(A-TYPE)	노루발(조)	1조	
F-11	05-012A-1230	B, B-7	Presser Foot Ass'y(B-TYPE)	노루발	1조	
F-12	05-012A-235B	BH, BH-7	Presser Foot Ass'y(BH-TYPE)	노루발(MAGRIN)	1조	
F-13	SC-0157-1230		Screw(9/64" n=40)	노루발 쥘나사(9/64" n=40)	1	
F-14	01-010A-1600		Thread Guide Plate	실걸이판	1	
F-15	SC-0502-2302		Screw(9/64" n=40)	윗뚜껑 고정판 조정나사(데)(9/64" n=40)	1	
F-16	43-001A-2500		Presser Lifter	누름대 올리기	1	
F-17	02-019W-1230		Washer For F-16	상축 헬트 와셔	1	
F-18	SC-0528-1230		Screw(9/64" n=40)	톱커버 나사(우)(9/64" n=40)	1	
F-19	43-102A-2500		Presser Lifter Cam Shaft	누름대 올리기 캠축	1	
F-20	02-016R-1230		O-Ring For F-19	상축 유량 조절핀 오링	1	
F-21	43-103A-2500		Presser Lifter Link	누름대 올리기 링크	1	
F-22	43-004S-2500		Hinge Screw For F-21	누름대 올리기 링크 힌지나사	2	
F-23	04-009C-3710		E-Ring(φ5)	E링(φ5)	5	
F-24	43-105A-2500		Presser Lifter Lever	누름대 올림 레버	1	
F-25	43-106C-2500		Presser Lifter Connection Bar	누름대 올리기 연결봉	1	
F-26	43-007S-2500		Stud Screw For F-25	누름대 올리기 연결봉 단나사	1	
F-27	43-108A-2500		Knee Lifting Link	무릎 올림 링크	1	
F-28	43-014S-1600		Hinge Screw For F-27	무릎 올림 링크 힌지나사	1	
F-29	43-109C-2500		Knee Lifting Bar	무릎 올림봉	1	
F-30	43-010S-2500		Hinge Screw For F-29	무릎 올림봉 힌지나사	1	
F-31	40-003P-2500	A, A-7	Tension Release Pin	실 늦추기 핀	1	
F-32	40-105C-2500		Tension Release Plate	실 늦추기 판	1	
F-33	40-006S-2500		Stud Screw For Tension Release Plate	실 늦추기 판 힌지나사	1	
F-34	04-009C-3710		E-Ring(φ5)	E링(φ5)	2	
F-35	40-007G-2500		Spring For Tension Release Plate	실 늦추기 판 스프링	1	
F-36	40-008A-2500	A-7, B-7	Tension Release Cable Ass'y	실늦추기 케이블(組)	1조	
F-37	40-209A-257A	A-7, B-7	Tension Release Cable Holder(U)	실늦추기 케이블잡이(U)	1	
F-38	SC-0516-3500	A-7, B-7	Screw(3/16" n=28)	가스킷 쥘나사(3/16" n=28)	1	
F-39	SC-0175-1230	A-7, B-7	Screw(11/64" n=40)	와이롯드 보강판 나사(11/64" n=40)	1	
F-40	40-003A-2700	A-7, B-7	Cable Connection Bolt	케이블 연결 볼트	1	
F-41	40-005C-2700	A-7, B-7	Nut For Cable Connection Bolt "B"	케이블 연결 너트"B"	1	
F-42	40-004C-2700	A-7, B-7	Nut For Cable Connection Bolt "A"	케이블 연결 너트"A"	1	
F-43	44-026G-7400	A-7, B-7	Tension Release Cable Holder(M)	헬트 잡이 스프링	1	
F-44	SC-0548-7400	A-7, B-7	Screw(3/16" n=28)	다이알 판 나사(3/16" n=28)	1	
F-45	40-211A-257A	A-7	Tension Release Cable Holder(L)(φ5)	실늦추기 케이블 잡이(L)	1	
F-46	SC-0175-1230	A-7, B-7	Screw(11/64" n=40)	와이롯드 보강판 나사(11/64" n=40)	1	
F-47	40-210A-257A	B-7	Tension Release Cable Holder(φ5)	케이블 잡이	1	

NOTE:

A-7=KM-250A-7S
 B-7=KM-250B-7S
 A=KM-250A
 B=KM-250B

☐=Common Part



Thread Wiper Mechanism 와이퍼 관계

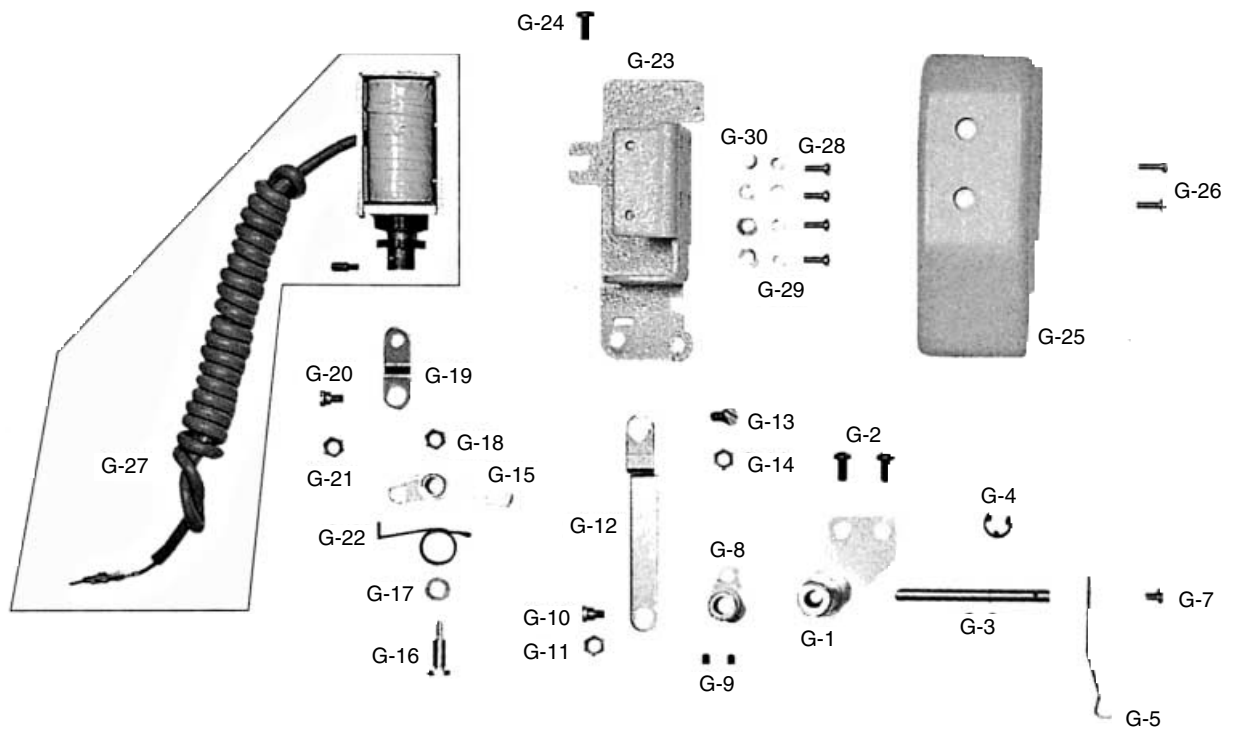

Ref. No.	Parts No.	Note	Name of Parts	품 명	Q' ty	Assembly No.
G-1	11-001A-257A	A-7, B-7	Wiper Bracket Ass'y	와이퍼 브라켓(組)	1조	
G-2	SC-0548-7400	A-7, B-7	Screw(3/16" n=28)	다이알 판 쥘나사(3/16" n=28)	2	
G-3	11-102A-257A	A-7, B-7	Wiper Rotation Shaft	와이퍼 회전축	1	
G-4	04-009C-3710	A-7, B-7	E-Ring(φ 5)	E링(φ 5)	1	
G-5	11-003A-257A	A-7, B-7	Wiper	와이퍼	1	
G-7	SC-0120-1230	A-7, B-7	Screw(9/64" n=40)	오일 펌프 커버 나사(9/64" n=40)	1	
G-8	11-106A-257A	A-7, B-7	Wiper Crank Ass'y	와이퍼 크랭크(組)	1조	
G-9	SC-0105-7500	A-7, B-7	Screw(M4)	등메스 축 카라 고정나사(M4)	1	
G-10	16-113S-3710	A-7, B-7	Hinge Screw For G-8	지그자그 연결링크 단나사(도금)	1	
G-11	SN-0101-1600	A-7, B-7	Nut(11/64" n=40)	스프링결이 축 나사 너트(11/64" n=40)	1	
G-12	11-007A-257A	A-7, B-7	Wiper Rod	와이퍼 로드	1	
G-13	16-113S-3710	A-7, B-7	Hinge Screw For G-12	지그자그 연결링크 단나사(도금)	1	
G-14	SN-0101-1600	A-7, B-7	Nut(11/64" n=40)	스프링결이 축 나사너트(11/64" n=40)	1	
G-15	11-008A-257A	A-7, B-7	Wiper Driving Link Ass'y	와이퍼 요동링크(組)	1조	
G-16	11-009S-257A	A-7, B-7	Hinge Screw For G-15	와이퍼 요동링크 힌지나사	1	
G-17	10-020W-2700	A-7, B-7	Washer For G-15	스토파 쥘와셔	1	
G-18	SN-0101-1600	A-7, B-7	Nut(3/16" n=32)	스프링결이 축 나사 너트(3/16" n=32)	1	
G-19	11-010A-257A	A-7, B-7	Wiper Solenoid Connection Link	와이퍼 솔레노이드 연결링크	1	
G-20	16-113S-3710	A-7, B-7	Hinge For G-19	지그자그 연결링크 단나사(도금)	1	
G-21	SN-0101-1600	A-7, B-7	Nut(11/64" n=40)	스프링결이 축 나사 너트(11/64" n=40)	1	
G-22	11-011G-257A	A-7, B-7	Wiper Spring	와이퍼 스프링	1	
G-23	11-112A-257A	A-7, B-7	Wiper Base	와이퍼 베이스	1	
G-24	SC-0548-7400	A-7, B-7	Screw(3/16" n=28)	다이알 판 쥘나사(3/16" n=28)	3	
G-25	11-013C-257A	A-7, B-7	Wiper Cover	와이퍼 커버	1	
G-26	SC-0120-1230	A-7, B-7	Screw(9/64" n=40)	오일펌프 커버 나사(9/64" n=40)	2	
G-27	11-015A-2507	A-7, B-7	Wiper Solenoid Ass'y	와이퍼 솔레노이드(SWP-5)	1조	
G-28	SC-0196-2700	A-7, B-7	Screw(M3×0.5)	솔레노이드 부착 고정나사(M3×0.5)	4	
G-29	11-016W-2700	A-7, B-7	Spring Washer For G-27	솔레노이드 부착 스프링 와셔	4	
G-30	11-017W-2700	A-7, B-7	Washer For G-27	솔레노이드 부착 평와셔	4	

NOTE:

A-7=KM-250A-7S
 B-7=KM-250B-7S
 A=KM-250A
 B=KM-250B

=Common Part

Reverse Button Mechanism 역진 버튼 관계

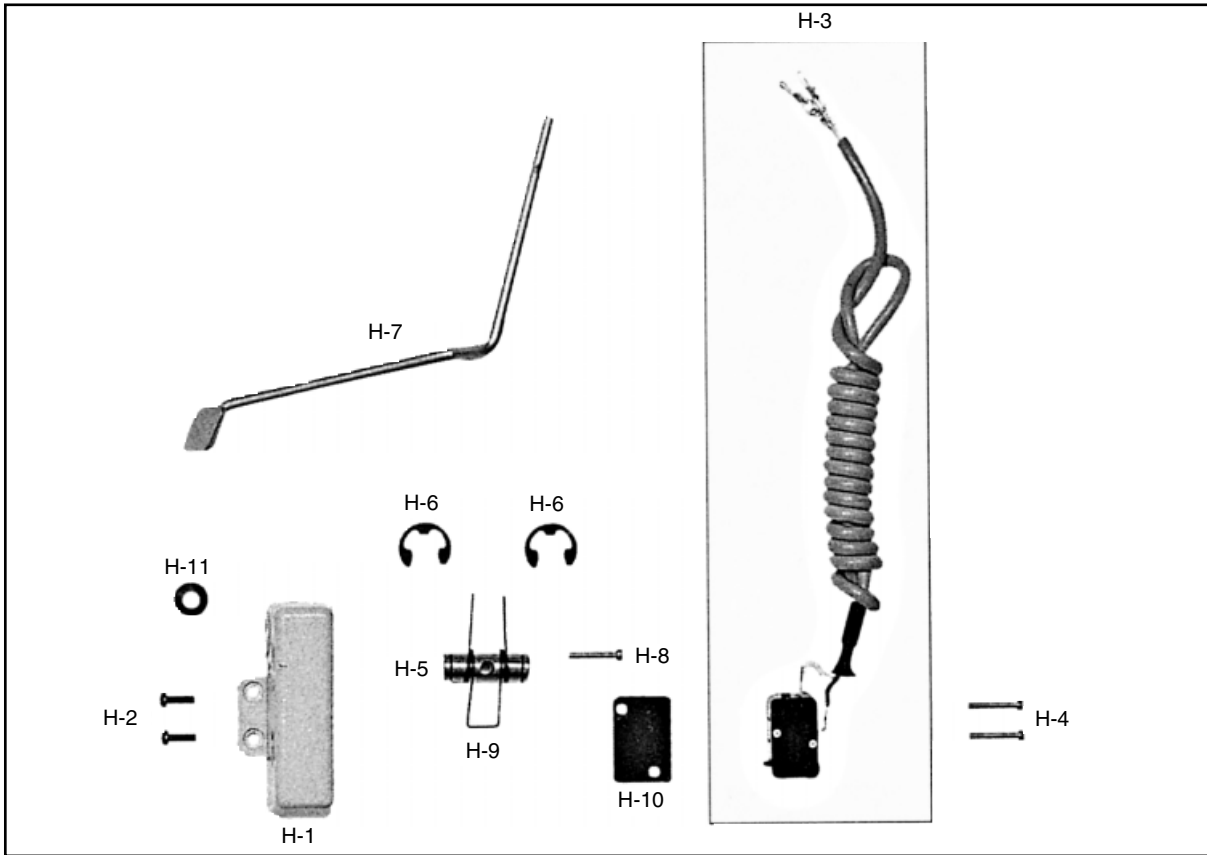

Ref. No.	Parts No.	Note	Name of Parts	품 명	Q' ty	Assembly No.
H-1	12-001A-5607	A-7, B-7	Reverse Button Case	보턴 케이스	1	
H-2	SC-0523-1230	A-7, B-7	Screw(9/64" n=40)	무릎 올림 링크 고정나사(9/64" n=40)	2	
H-3	12-131A-5607	A-7, B-7	Reverse Button S/W Ass'y	역진 보턴 스위치(조)	(2)	H-3
H-4	12-012S-2700	A-7, B-7	Screw	홈볼이 동근납작 작은나사	2	
H-5	12-104P-5607	A-7, B-7	Reverse Button Actuator Pin	역진 보턴 작동핀	1	
H-6	43-009C-1600	A-7, B-7	E-Ring(φ 9)	제어체 축링(E링9)	2	
H-7	12-101A-257A	A-7, B-7	Reverse Feed Control Lever	역진 작동 레버(組)	1	
H-8	SC-0178-7400	A-7, B-7	Screw(11/64" n=40)	윗뚜껑 쥘나사(좌)(11/64" n=40)	1	
H-9	12-008G-5607	A-7, B-7	Spring For H-7	역진 보턴 스위치 누름대 S/P	1	
H-10	12-009R-5607	A-7, B-7	Insulated Rubber	스위치 받침 절연 고무	1	
H-11	12-010A-5607	A-7, B-7	Reverse Button Cable Bushing	역진 보턴 케이블 붓싱	1	

NOTE:

A-7=KM-250A-7S
 B-7=KM-250B-7S
 A-7=KM-250A
 B-7=KM-250B
 □=Common Part

Lubrication 급유관계

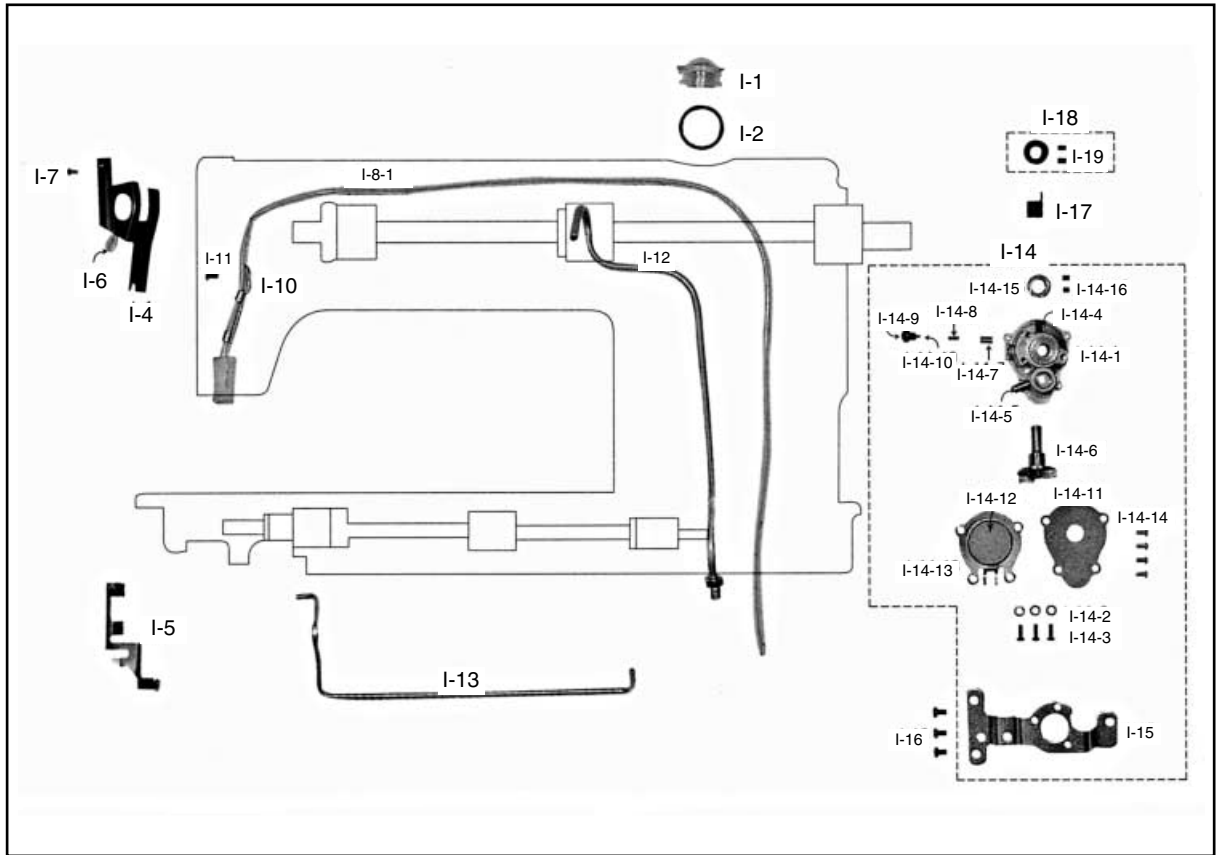

Ref. No.	Parts No.	Note	Name of Parts	품명	Q'ty	Assembly No.
I-1	44-001C-2500		Oil Gauge Window	유창	1	
I-2	44-002R-2500		O-Ring For I-1	유창 오링 (G25)	1	
I-4	44-120A-1600	A, A-7	Arm Oil Shield	면판 유방판	1	
I-5	44-131C-1230	B, B-7	Arm Oil Shield	바늘대 급유판	1	
I-6	44-0000-1230		Oil Wick	오일심지	1	
I-7	SC-0120-1230		Screw(9/64" n=40)	오일펌프 커버 나사(9/64" n=40)	1	
I-8-1	44-012C-1230		Oil Return Tube	환류 파이프	1	
I-10	44-117A-1600		Oil Return Tube Holder	환류 파이프 잡이	1	
I-11	SC-0548-7400		Screw(3/16" n=28)	다이알 판 쥘나사(3/16" n=40)	1	
I-12	44-008P-2500		Upper Shaft Oil Pipe Ass'y	상축 급유 파이프(組)	1	
I-13	44-009P-2500		Oil Pipe For Lower Shaft	하축 급유 파이프	1	
I-14	44-150A-2500		Oil Pump Ass'y	오일펌프(조)	1	
I-14-1	44-012A-2350		Oil Pump Body	오일 펌프 몸체	(1)	I-14
I-14-2	44-011W-1600		Washer For I-14-1	오일 펌프 몸체 쥘나사 와셔(40)	(3)	
I-14-3	SC-0528-1230		Screw(9/64" n=40)	톱커버 나사(우)(9/64" n=40)	(3)	
I-14-4	44-010C-1600		Nipple For Oil Return Pipe	환류 파이프 니플	(1)	
I-14-5	44-009C-1600		Oil Nipple For Lower Shaft	하축 급유 니플	(1)	
I-14-6	44-126A-1230		Impeller	임펠러	(1)	
I-14-7	44-117A-1230		Piston	피스톤	(1)	
I-14-8	44-118G-1230		Piston Spring	피스톤 스프링	(1)	
I-14-9	44-119S-1230		Pin Screw For I-14-8	피스톤 스프링 쥘나사	(1)	
I-14-10	44-120P-1230		Pin For I-14-8	피스톤 스프링 핀 (RP 2×8)	(1)	
I-14-11	44-104C-2350		Cover For Oil Pump	오일 펌프 커버	(1)	
I-14-12	44-024C-1230		Oil Pump Cap	오일 펌프 헬터 캡	(1)	
I-14-13	44-105C-2350		Magnetic Holder	자석잡이	(1)	
I-14-14	44-120S-1230		Screw(9/64" n=40)	오일 펌프 커버 나사(+2.5mm)	(4)	
I-14-15	44-119A-1230		Collar For Impeller Shagt	오일 펌프 카라	(1)	
I-14-16	SC-0512-1230		Screw(11/64" n=40)	오일 펌프 조인트 나사(11/64" n=40)	(2)	
I-15	44-010A-2500		Oil Pump Bracket	오일 펌프 브라켓	1	
I-16	SC-0548-7400		Screw(3/16" n=28)	다이알 판 쥘나사(3/16" n=28)	3	
I-17	44-016G-1230		Oil Pump Connection Spring	오일 펌프 조인트 스프링	1	
I-18	44-115A-1230		Oil Pump Connection Collar	오일 펌프 조인트 카라(조)	1	
I-19	SC-0542-1230		Screw(11/64" n=40)	실닛추기 고정나사(11/64" n=40)	2	

NOTE:

A-7=KM-250A-7S
 B-7=KM-250B-7S
 A-7=KM-250A
 B-7=KM-250B
 □=Common Part

J

Accessories 악세서리

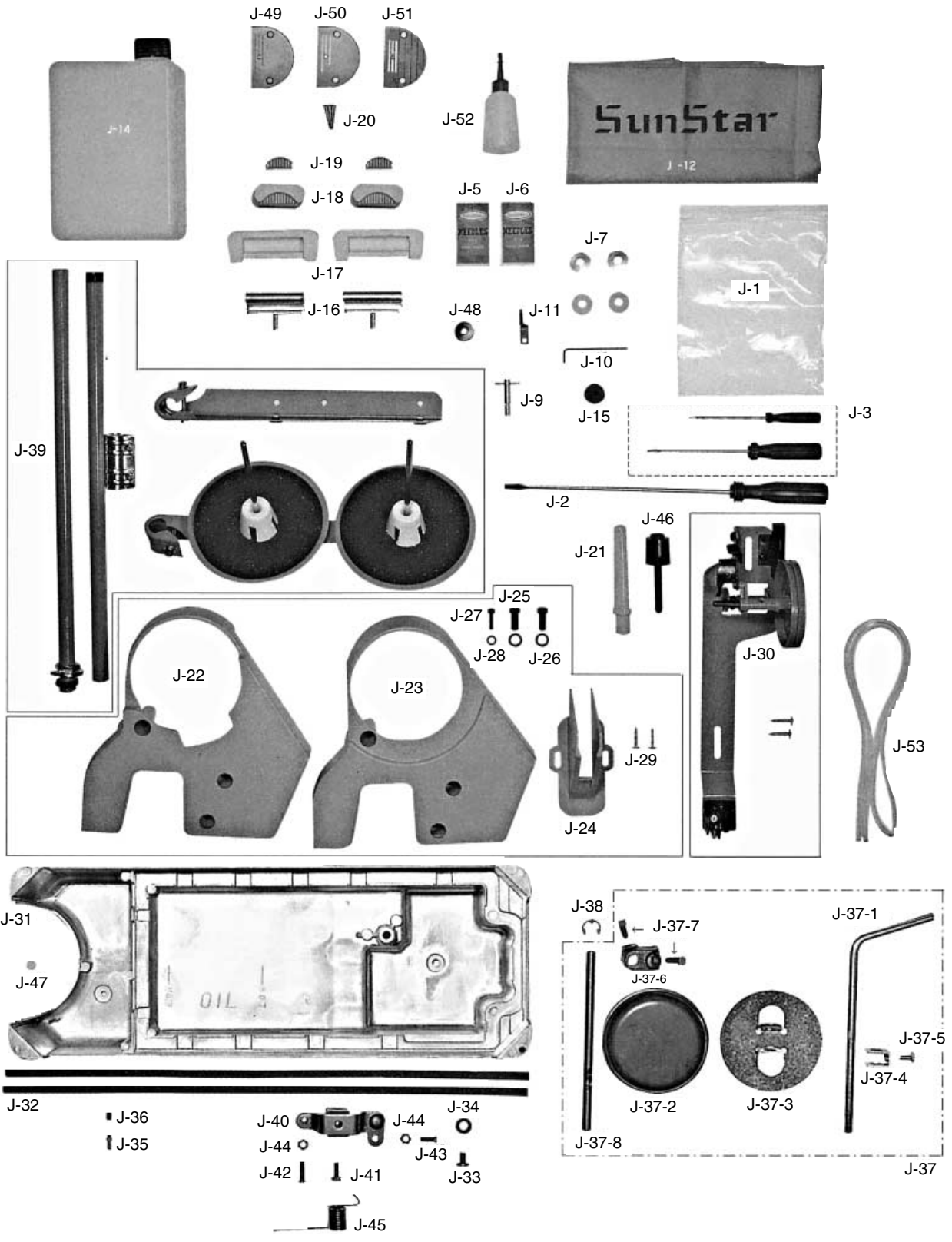

Ref. No.	Parts No.	Note	Name of Parts	품 명	Q' ty	Assembly No.
J-1	91-001C-1230		Accessory Bag	악세서리 박스	1	
J-2	91-102C-1230		Driver(Large)	드라이버(大)	1	
J-3	91-103C-1230		Driver(Middle, Small)	드라이버(中,小)	1	
J-5			Needle(A-Type)	바늘(A형)	5	
J-6			Needle(B-Type)	바늘(B형)	5	
J-7	07-105A-2700		Bobbin(AL)	보빈	4	
J-9	91-105C-2700	A-7, B-7	Spanner	고정메스 장력 조절용 스패너	1	
J-10	91-001C-2700	A-7, B-7	L Wrench(2mm)	L 렌치(2mm)	1	
J-11	10-201A-2700	A-7, B-7	Fixed Mes	고정메스(극진사용)	1	
J-12	91-106C-2700	A-7, B-7	Head Cover	미싱커버(대)	1	
J-14	91-008C-1230		Oil Tank	오일 캔	1	
J-15	44-010C-1230		Magnetic	자석	1	
J-16	01-043C-1230		Head Hinge	힌지	2	
J-17	01-042R-1230		Rubber Cushion For Hinge	힌지 고무(대)	2	
J-18	01-241R-1230		Head Support Rubber "A"	힌지 고무(중)	2	
J-19	01-213R-1230		Head Support Rubber "B"	힌지 고무(소)	2	
J-20			Nail	못	4	
J-21	91-012C-1230		Head Rest	미싱 받침대	1	
J-22	60-001A-2500	A-7, B-7	Belt Cover "A"	벨트 커버 A(SERVO)	1	
J-23	60-003A-2500	7N	Belt Cover "A" (FOR NP MOTOR)	벨트 커버 A(NP)	1	
J-24	60-002A-2500		Belt Cover "B"	벨트 커버 "B"	1	
J-25	SC-0344-8260		Screw(5/16" n=24)	포스트 고정나사(5/16" n=24)	2	
J-26	09-025W-8270		Washer For J-22,23	새들 컵나사 와셔	2	
J-27	SC-0184-4118		Screw(3/16" n=28)	홈볼이 넵비 작은나사(3/16" n=28)	1	
J-28	10-020W-2700		Washer For J-22,23	스토퍼 컵와셔	1	
J-29	91-002S-3400		Nail For J-24	목나사	2	
J-30	41-101A-1230		Bobbin Winder Ass'y	실감기(組)	1조	
J-31	44-012A-2500		Oil Pan	오일팬	1	
J-32	44-003M-1230		Oil Pan Gasket	오일팬 가스켓	2조	
J-33	SC-0347-1230		Screw(M8×1.25)	배유 구멍 마개 나사(M8×1.25)	1	
J-34	44-005R-1230		Packing For J-33	배유 구멍 마개 나사 오링	1	
J-35	44-032C-1230		Oil Pan Nipple	오일팬 니플	1	
J-36	SC-0509-1230		Screw(15/64" n=28)	피이드 캠 고정나사	1	
J-37-1	43-106C-1600		Knee Lifter Shaft	무릎 받침축	1	J-37
J-37-2	43-101R-1600		Knee Lifter Pad	무릎 받침 고무	1	
J-37-3	43-102C-1600		Knee Lifter Pad Insert Plate	무릎 받침 고무잡이판	1	
J-37-4	43-101A-1230		Holder For J-37-2	무릎 받침 고무 연결 링크	1	
J-37-5	43-108S-1230		Set Screw For J-37-4	무릎 받침 연결링크 컵나사	1	
J-37-6	43-106C-1230		Knee Lifter Arm Joint Complete	무릎 받침 연결 크랭크	1	
J-37-7	SC-0181-1230		Screw(5/16" n=18)	무릎 받침 축 고정나사(5/16" n=18)	2	
J-37-8	43-108C-1600		Shaft For J-40	제어체 축	1	
J-38	43-009C-1600		E-Ring(φ9)	제어체 축 링(E링 φ9)	1	
J-39	91-007A-2302		Thread Stand Ass'y	실패꽃이(組)	1조	
J-40	43-007A-1600		Knee Lifting Controller	제어체	1	
J-41	SC-0106-7400		Screw(15/64" n=28)	포크 컵나사(육각)(15/64" n=28)	1	
J-42	SC-0545-1230		Screw(15/64" n=28)	제어체 운동조절나사(중)(15/64" n=28)	1	
J-43	SC-0546-1230		Screw(15/64" n=28)	제어체 운동조절나사(대)(15/64" n=28)	1	
J-44	SN-0105-3400		Nut(15/64" n=28)	수평운동 조절 축 너트(15/64" n=28)	2	
J-45	43-008G-1600		Spring For J-40	제어체 스프링	1	
J-46	43-010A-1600		Knee Base Rubber	무릎 올림봉 받침 캡	1	
J-47	04-104R-1230	7N	Rubber Cap For J-31	바늘대 상 붓싱 마개(흰색)40	1	
J-48	44-011R-2350		Packing	오일팬 누유방지 고무	1	
J-49	01-135A-123A	A, A-7	Needle Plate(A-Type)	침판(A형)	1	
J-50	01-135A-123B	B, B-7	Needle Plate(B-Type)	침판(B형)	1	
J-51	06-135A-235B	BH	Needle Plate(BH-Type)	침판(BH형)	1	
J-52	91-011C-1230		Oil Tank	유차	1	
J-53	44-012C-1230		Oil Return Tube	환류 파이프	1	

NOTE:

A-7=KM-250A-7S
 B-7=KM-250B-7S
 A=KM-250A
 B=KM-250B
=Common Part

Program Unit Box & Pressor Lifting Solenoid Mechanism

프로그램 유닛 박스 및 자동 무릎 올림 관계

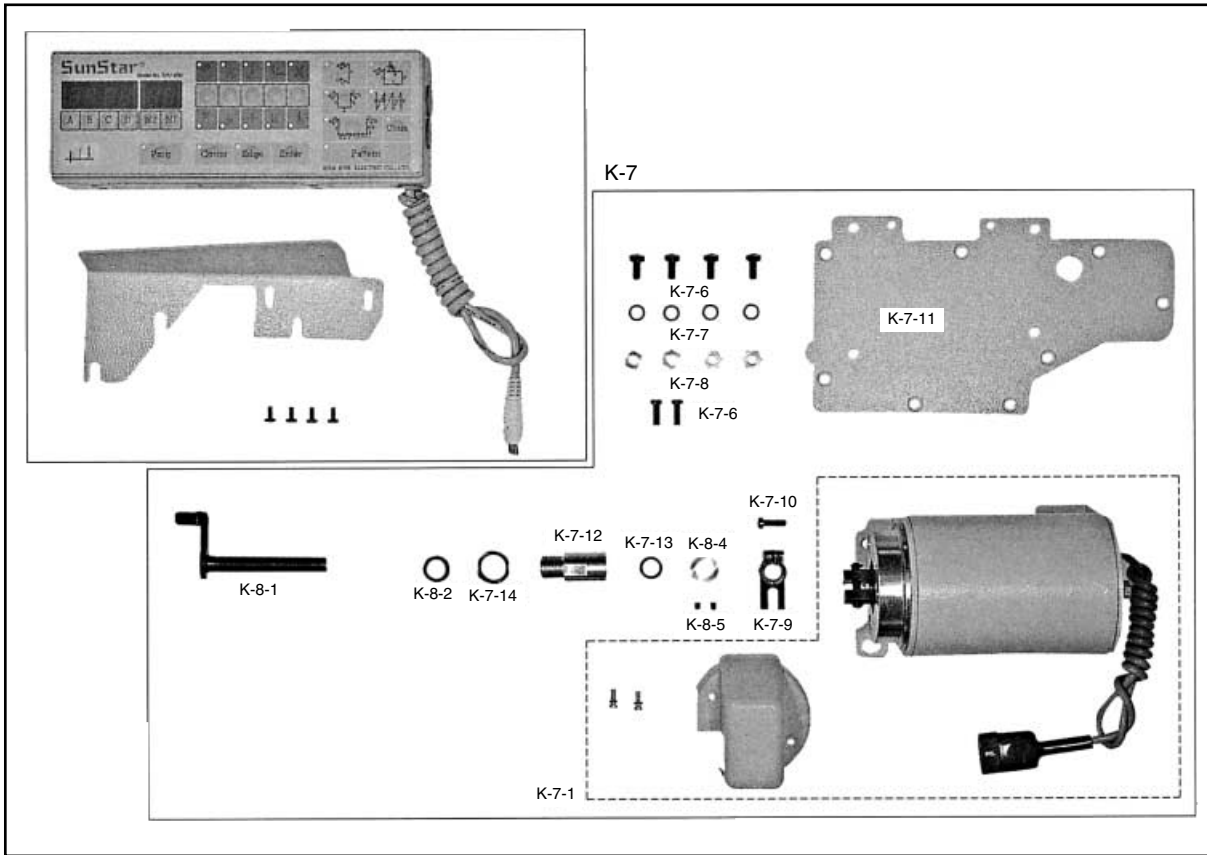

Ref. No.	Parts No.	Note	Name of Parts	품 명	Q' ty	Assembly No.
K-7	KM-2507	A-7, B-7	Auto Knee Lifter Solenoid Ass'y	자동무릎 올림 솔레노이드(조)	1	
K-7-1	HEC-2507	A-7, B-7	Auto Knee Lifter Solenoid Ass'y	자동무릎 올림장치(SPF-5)	(1조)	
K-7-6	SC-0183-2700	A-7, B-7	Screw(15/64" n=28)	베이스 고정나사 B(15/64" n=28)	(4)	K-7
K-7-7	06-051W-7400	A-7, B-7	Washer For K-7-4, K-7-5	포크 쥘나사 와셔	(4)	
K-7-8	SN-0121-7400	A-7, B-7	Nut(15/64" n=28)	세구멍 실결이 너트(15/64" n=28)	(4)	
K-7-9	43-013A-257A	A-7, B-7	Knee Lifter Connection Crank	자동무릎올림 연결 크랭크(AK)	(1)	
K-7-10	SC-0497-1230	A-7, B-7	Screw(3/16" n=28)	들레크랭크(전) 고정나사(3/16" n=28)	(1)	
K-7-11	43-014A-257A	A-7, B-7	Back Cover For Knee Lifter	자동 무릎 올림 뒷뚜껑 AK	(1)	
K-7-12	43-015A-257A	A-7, B-7	Knee Lifter Shaft Bushing	자동 무릎 올림축 붓싱 AK	(1)	
K-7-13	43-016R-257A	A-7, B-7	Oil Seal For K-7-12	자동 무릎 올림축 오일셀 AK	(1)	
K-7-14	43-017C-257A	A-7, B-7	Nut For Knee Lifter	자동 무릎 올림 너트 AK	(1)	
K-8-1	43-018A-257A	A-7, B-7	Knee Lifter Shaft	자동 무릎 올림축(조) AK	(1)	
K-8-2	06-021W-7400	A-7, B-7	Washer For K-8-1	역진 레마 와셔	(1)	
K-8-4	43-021A-257A	A-7, B-7	Collar For K-8-1	자동 무릎 올림축 카라 AK	(1)	
K-8-5	SC-0512-1230	A-7, B-7	Screw(11/64" n=40)	오일펌프 조인트 나사(11/64" n=40)	(2)	
K-8-6	SC-0548-7400		Screw	다이알 판 쥘나사	(2)	

NOTE:

A-7=KM-250A-7S
 B-7=KM-250B-7S
 A=KM-250A
 B=KM-250B
 Common Part

NOTE : K-7-15, K-7-16, K-8-3 Deleted Parts List



Special Parts For KM-250AU Series KM-250AU 시리즈 전용 부품관계

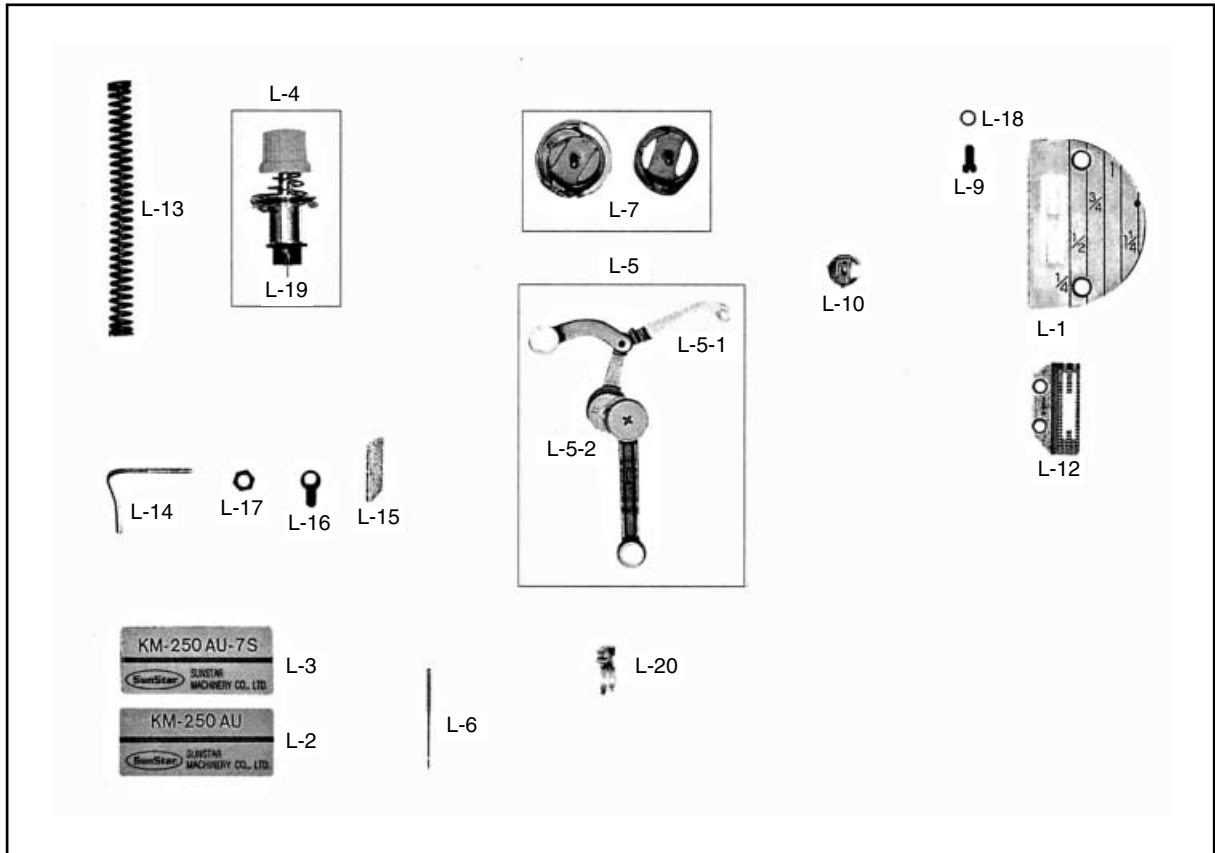

Ref. No.	Parts No.	Note	Name of Parts	품명	Q'ty	Assembly No.
L-1	01-135A-235A		Needle Plate(AU-Type)	박물용 침판	1	
L-2	01-045M-257U		Model Mark(KM-250AU)	모델마크	1	
L-3	01-045M-250U		Model Mark(KM-250AU-7S)	모델마크	1	
L-4	40-004A-257U		Thread Tension Control Ass'y	실조절 장치	(1조)	
L-5	08-101A-257U		Thread Take-Up Lever Ass'y	실채기(110-91857)	(1조)	
L-6			Needle(AU-Type)	바늘	1	
L-7	07-003A-257U		Oil-Less Rotary Hook Ass'y(For Thread Trimmer)	가마HSH-7.94BTR(P)	1조	
L-9	07-005S-250U		Oil Protection Screw For Lower Shaft	하축 급유 마개 나사	1	
L-10	07-106A-123A		Bobbin Case Ass'y	보빈 케이스	1조	
L-12	06-107A-257U		Feed Dog(AU-Type)	박물용 톱니	1	
L-13	05-014C-257U		Presser Adjusting Spring	압력 조절 스프링	1	
L-14	05-013C-257U		Arm Thread Guide(L)	Arm 실안내(L)	1	
L-15	05-115C-257U		Arm Thread Guide Holder Plates	Arm 실안내 잡이판	1	
L-16	05-116W-257U		Washer For Arm Thread Guide	Arm 실안내 고정와셔	1	
L-17	11-017C-7507		Nut For Arm Thread Guide	와이퍼 링크 A 연결 단나사 너트	1	
L-18	07-004R-250U		O-Ring For L-9	하축급유 마개나사 오링	1	
L-19	40-008R-1230		Cap For Tension Release Pin	실 늦추기 핀 캡	1	
L-20	05-005A-1600		Presser Foot	노루발	1	

M

Special Parts For

[KM-250AU-7N · KM-250A-7N · KM-250B-7N]

[KM-250AU-7N · KM-250A-7N · KM-250B-7N] 전용 부품관계

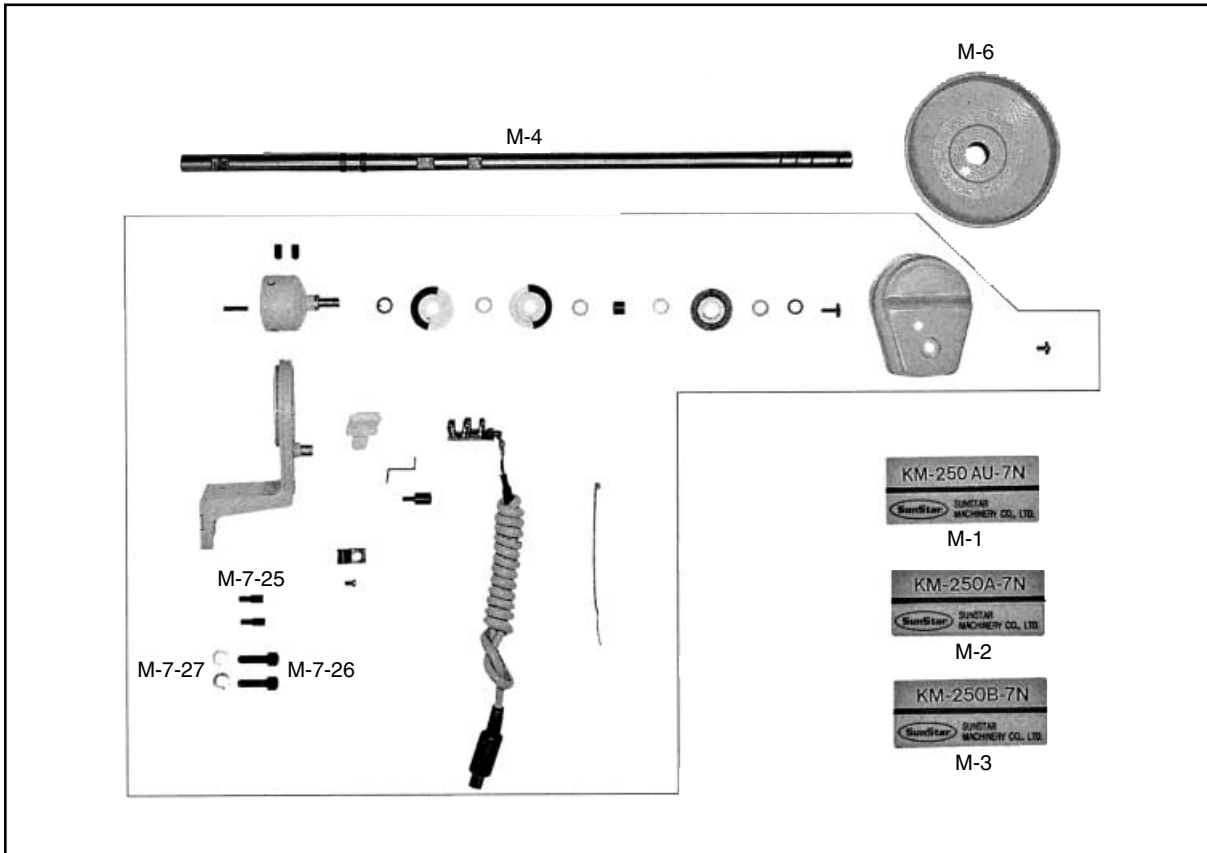

Ref. No.	Parts No.	Note	Name of Parts	품 명	Q' ty	Assembly No.
M-1	01-45NP-257U		Model Mark(KM-250AU-7N)	모델마크(KM-250AU-7N)	1	
M-2	01-45NP-257A		Model Mark(KM-250A-7N)	모델마크(KM-250A-7N)	1	
M-3	01-45NP-257B		Model Mark(KM-250B-7N)	모델마크(KM-250B-7N)	1	
M-4	02-101A-257N		Upper Shaft(NP-Type)	상축(NP용: L = 431mm)	1	
M-6	02-003A-2350		Pulley	풀리	1	
M-7-25	01-019P-2350		Guide Pin For Synchronizer	싱크로 베이스 기준핀	(2)	
M-7-26	SC-0108-4113		Screw(M6)	육각구멍볼이 보울트(M6)	(2)	12-0000-4701 싱크로 (외장형)-N.P
M-7-27	01-020W-2350		Washer For Synchronizer	싱크로 베이스 스프링 와셔(φ6)	(2)	

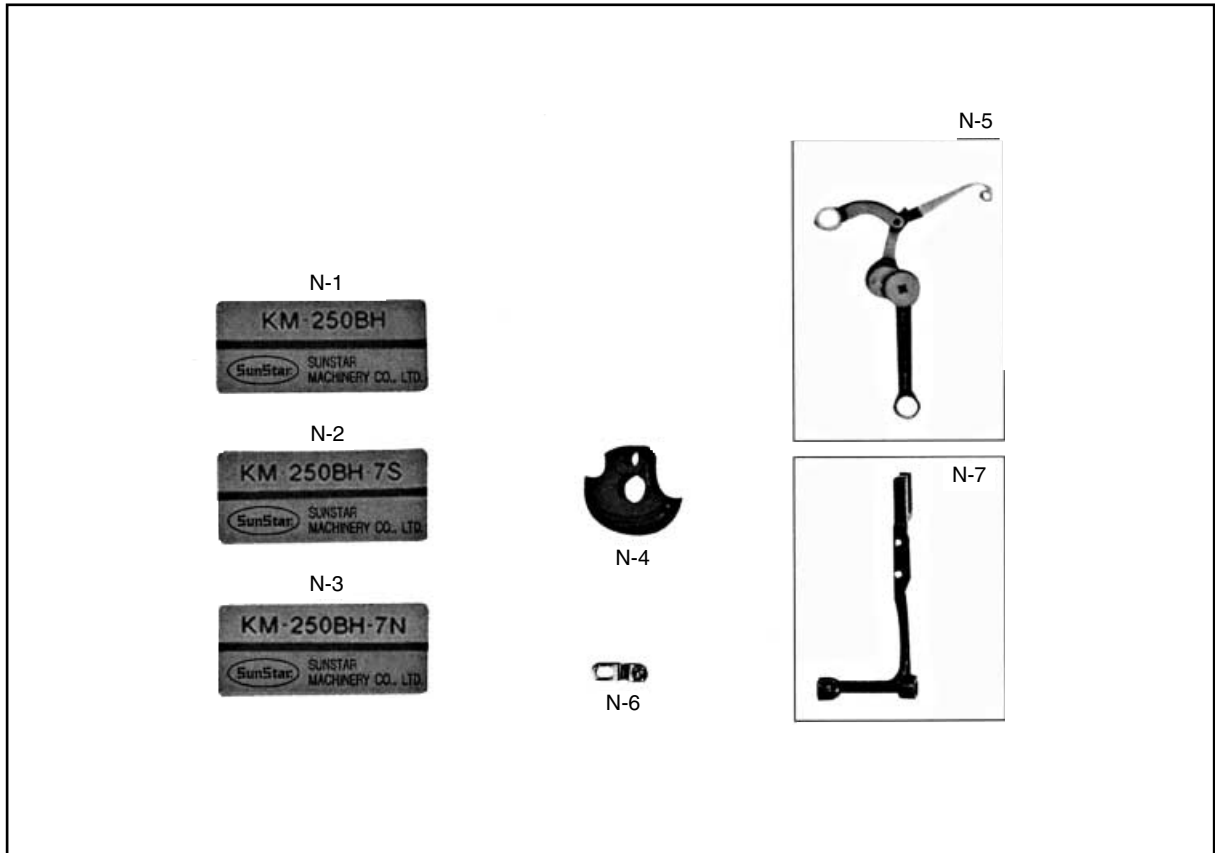

Ref. No.	Parts No.	Note	Name of Parts	품 명	Q' ty	Assembly No.
N-1	01-045M-250H		Model Mark(KM-250BH)	모델마크(KM-250BH)	1	
N-2	01-045M-257H		Model Mark(KM-250BH-7S)	모델마크(KM-250BH-7S)	1	
N-3	01-45NP-257H		Model Mark(KM-250BH-7N)	모델마크(KM-250BH-7N)	1	
N-4	01-102A-250H		Link Cam(BH-Type)	링크캠(BH形)	1	
N-5	08-101A-25BH		Thread Take-Up Lever Ass'y	실채기(조)	1	
N-6	01-003C-250B		Thread Guide For A-5	면판 실결이	1	
N-7	06-315A-2350		Feed Bar(BH-Type)	톱니 받침	1	



Special Parts For KM-250BL Series

KM-250BL 시리즈 전용 부품 관계

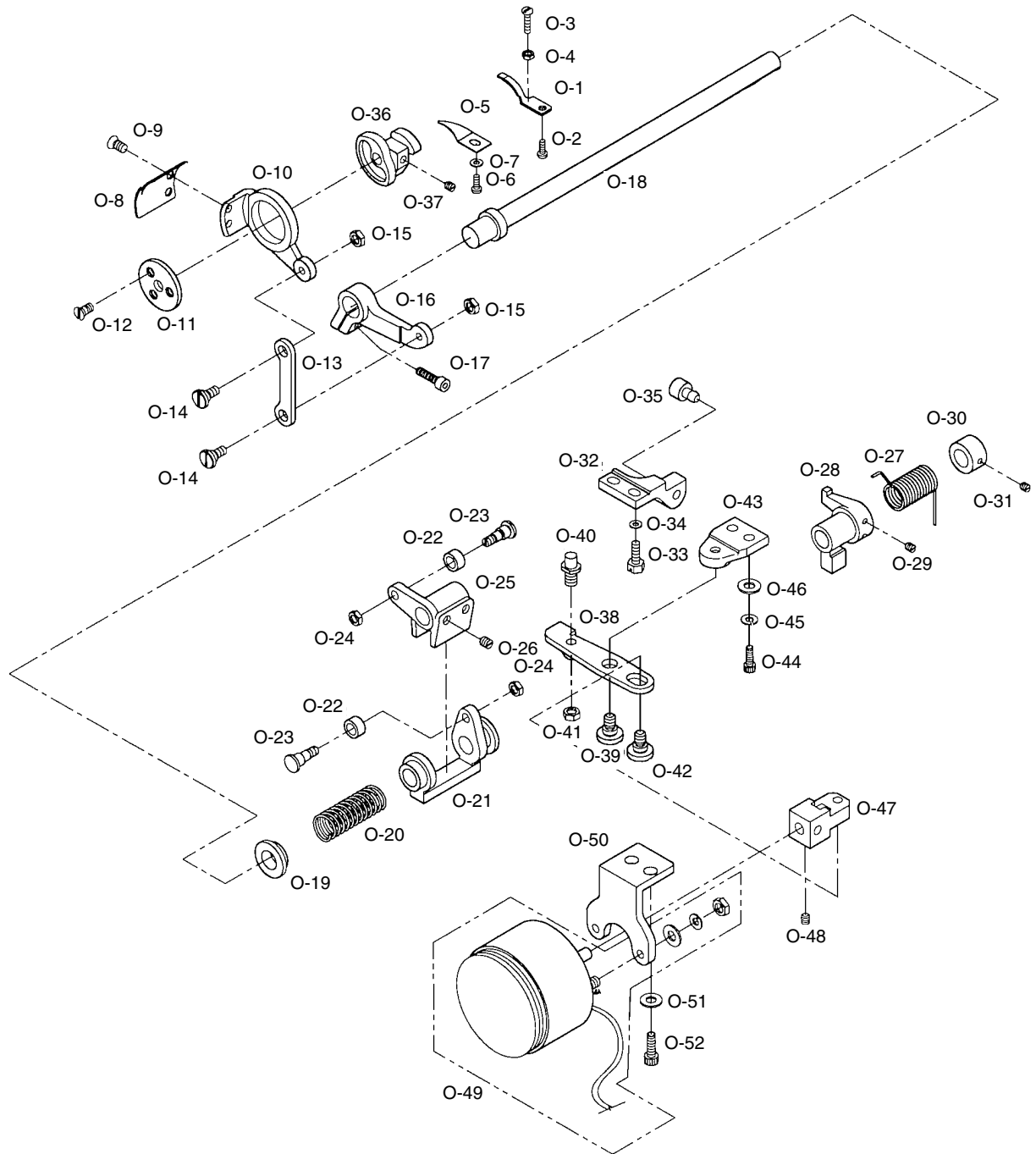

Ref. No.	Parts No.	Note	Name of Parts	품 명	Q' ty	Assembly No.
O-1	10-101A-64L7		Fixed Mes	고정메스	1	
O-2	SC-A301-4119		Screw(9/64" n = 40)	고정메스 고정나사(9/64" n=40)	1	
O-3	SC-0137-2700		Screw(1/8" n = 40)	고정메스장력 조절나사(1/8" n=40)	1	
O-4	SN-0103-2700		Nut(1/8" n = 40)	고정메스 장력조절나사 너트(1/8" n=40)	1	
O-5	10-005A-64L7		Thread Retaining Plate	실가리개	1	
O-6	SC-0543-2302		Screw(11/64" n = 40)	툽커버 힌지 고정나사(11/64" n=40)	1	
O-7	02-019W-1230		Washer For O-5	실가리개 고정와셔	1	
O-8	10-106A-64L7		Rotary Mes	회전메스	1	
O-9	SC-A154-4115		Screw(11/64" n = 40)	회전메스 고정나사(11/64" n=40)	2	
O-10	10-110A-25BL		Thread Trimming Holder	사절홀더	1	
O-11	10-011C-64L7		Thread Trimming Holder Cover	사절홀더 커버	1	
O-12	SC-A301-4119		Screw(9/64" n = 40)	사절홀더 커버 고정나사(9/64" n=40)	3	
O-13	10-013C-64L7		Thread Trimming Lever Connecting Link	사절레버 연결링크	1	
O-14	10-014S-64L7		Stud Screw For O-13	사절레버 연결링크 단나사(3/16" n=32)	2	
O-15	SN-0115-7400		Nut For O-14	오프너 너트(3/16" n = 32)	2	
O-16	10-116A-64L7		Thread Trimming Lever	사절레버	1	
O-17	SC-0109-2350		Screw	역진 솔레노이드 브라켓 쥘나사(M6×P1)	1	
O-18	10-118A-64L7		Thread Trimming Shaft	사절축	1	
O-19	10-021C-64L7		Guide Bush For Return Spring	리턴 스프링 가이드 붓싱	1	
O-20	10-022G-64L7		Slide Arm Return Spring	슬라이드 암 리턴 스프링	1	
O-21	10-123A-64L7		Slide Arm	슬라이드 암	1	
O-22	10-066A-7507		Roller	사절캠 롤러	2	
O-23	10-067S-7507		Stud Screw For O-22	사절캠 롤러 단나사	2	
O-24	SN-0115-7400		Nut(3/16" n = 32)	오프너 너트(3/16" n = 32)	2	
O-25	10-127A-64L7		Cam Follwer Crank	사절캠 종동 크랭크	1	
O-26	SC-0169-1600		Screw(15/64" n = 28)	피이드 조절 크랭크 쥘나사(15/64" n=28)	2	
O-27	10-029G-64L7		Return Spring	사절축 리턴 스프링	1	
O-28	10-030A-64L7		Stopper Lever	스토퍼 레버	1	
O-29	SC-0317-2700		Screw(15/64" n = 28)	캠 접촉 안내 고정나사(15/64" n=28)	2	
O-30	06-220A-2350		Collar For O-18	사절축 카라	1	
O-31	SC-A308-4517		Screw(1/4" n = 40)	사절 캠 고정나사(1/4" n=40)	2	
O-32	10-118A-2700		Stopper	스토퍼	1	
O-33	SC-0190-2700		Screw(3/16" n = 32)	스토퍼 쥘나사(3/16" n = 32)	2	
O-34	10-020W-2700		Washer	스토퍼 쥘나사 와셔	2	
O-35	10-021R-270		Stopper Lever Cushion Rubber	스토퍼 레버 쿠션고무	1	
O-36	10-054A-64L7		Mes Cam	사절캠	1	
O-37	SC-A308-4517		Screw(1/4" n = 40)	사절캠 쥘나사(1/4" n = 40)	2	
O-38	10-038A-25BL		Cluth Lever	클러치 레버	1	
O-39	43-004S-3400		Stud Screw For O-38	클러치 레버 단나사(15/64" n=28)	1	
O-40	10-041S-64L7		Stud Screw For O-38	클러치 레버 작동 쥘나사(15/64" n=28)	1	
O-41	SN-0105-3400		Nut(15/64" n = 28)	수평운동 릿트 단나사(15/64" n=28)	1	
O-42	43-004S-3400		Stud Cres For O-47	솔레노이드 연결링크 단나사(15/64" n=28)	1	
O-43	10-044A-25BL		Base Plate	베이스 플레이트	1	
O-44	SC-0190-2700		Screw(M5×P0.8)	스토퍼 쥘나사(M5×P0.8)	2	
O-45	07-011W-1230		Spring Washer For O-44	가마잡이 와셔(φ 5)	2	
O-46	10-020W-2700		Washer For O-44	스토퍼 쥘와셔(φ 5)	2	
O-47	10-048A-25BL		Solenoid Connecting Link	솔레노이드 연결링크	1	
O-48	SC-0164-2700		Screw(M5xP0.8)	캠 접촉 카라 고정나사	2	
O-49	10-144A-2507		Thread Trimming Solenoid Ass'y	사절 솔레노이드(組)	1(조)	
O-50	10-151A-25BL		Base For O-49	사절 솔레노이드 베이스	1	
O-51	06-051W-7400		Washer For O-50	사절 솔레노이드 베이스 고정 와셔	1	
O-52	SC-0109-2350		Screw(M6×P1)	역진 솔레노이드 브라켓 쥘나사(M6×P1)	2	

P

Special Parts For KM-250BL Series KM-250BL 시리즈 전용 부품 관계

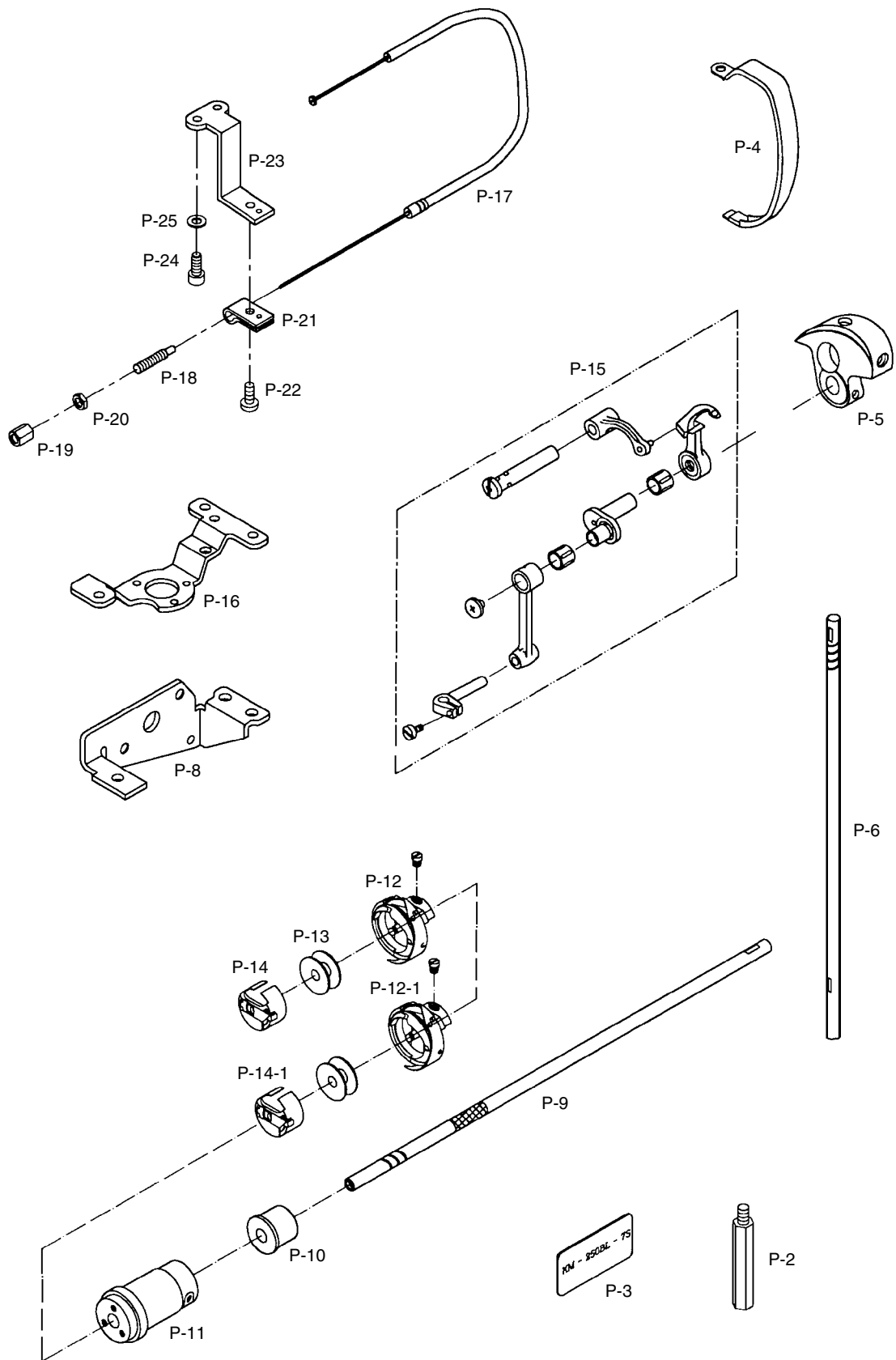

Ref. No.	Parts No.	Note	Name of Parts	품 명	Q' ty	Assembly No.
P-1	01-001A-25BL		Arm Bed	아암.베드	1	
P-2	01-105A-2350		Bed Base "Front"(B)	베드 받침 전(B)	1	
P-3	01-242M-25BL		Modle Mark(KM-250BL-7S)	모델 마크	1	
P-4	01-139C-2500		Thread Take up Cover	실채기 커버	1	
P-5	02-109A-25BL		Link Cam	링크 캠	1	
P-6	03-101A-1230		Upright Shaft	입축	1	
P-7	006-007-0005		Needle	바늘 DB×1(#21)	1	
P-8	06-190A-25BL		Bracket For Reverse Feed Solenoid	역진 솔레노이드 브라켓	1	
P-9	07-101A-25BL		Lower Shaft	하축	1	
P-10	07-009A-25BL		Lower Shaft Bushing(M)	하축 중 붓싱	1	
P-11	07-110A-25BL	BL	Lower Shaft Bushing(F)	하축 전 붓싱	1	
P-11-1	07-110A-2BLS	BL-7	Lower Shaft Bushing(F)	하축 전 붓싱	1	
P-12	07-024A-64L7	BL-7	Rotary Hook Ass'y	가마	1(조)	
P-12-1	07-007A-146L	250BL	Rotary Hook Ass'y	가마	1(조)	
P-13	07-225A-64L7		Bobbin	보빈(A1)	1	
P-14	07-026A-64L7	BL-7	Bobbin Case Assembly	보빈 케이스(조)	1(조)	
P-14-1	07-106A-146L	250BL	Bobbin Case Assembly	보빈 케이스(조)	1(조)	
P-15	08-102A-146L		Thread Take up Lever Assembly	실채기(조)	1(조)	
P-16	44-001A-25BL		Oil Pump Bracket	오일 펌프 브라켓	1	
P-17	40-001A-25BL		Tension Release Cable Ass'y	실눗추기 케이블(조)	1조	
P-18	40-003A-2700		Connecting Bolt For P-17	케이블 연결볼트	1	
P-19	40-004C-2700		Nut A For P-17	케이블 연결 너트 A	1	
P-20	40-005C-2700		Nut B For P-17	케이블 연결 너트 B	1	
P-21	40-140C-64L7		Tension Release Cable Holder(L)	실눗추기 케이블 잡이(하)	1	
P-22	SC-0543-2302		Screw	톱커버 힌지 고정나사	1	
P-23	40-142A-64L7		Bracket For P-21	실눗추기 케이블 잡이(하) 브라켓	1	
P-24	SC-0211-7500		Screw	고정메스 고정나사	2	
P-25	01-017W-1600		Washer	실눗추기 케이블 잡이(하) 브라켓 평와셔	361	



SUNSTAR MACHINERY CO., LTD.

HEAD OFFICE

178-212, GAJWA-DONG, SEO-KU, INCHON, KOREA
TEL : (032) 580-5600 ~ 4 FAX : (032) 584-3020

TRADE OFFICE

178-212, GAJWA-DONG, SEO-KU, INCHON, KOREA
TEL : (032) 580-5740 ~ 60 FAX : (032) 584-3025 ~ 6

OVERSEAS NETWORK

SUNSTAR MACHINERY U.S.A., INC.

11475, N.W. 39TH ST. Miami, Florida 33178, USA
TEL : 1-305-591-9596 FAX : 1-305-591-0661

SUNSTAR MACHINERY HONGKONG LTD.

RM. 1302, Apec Plaza, No. 49 Hoi Yuen RD,
Kwun Tong, Kln. H. K.
TEL : 852-2729-7078, 852-2729-7224 FAX : 852-2729-7573

SUNSTAR MACHINERY SHANG HAI LTD. (CHINA)

#7 Yuangong Rd. Shanghai International Automobiles City
Components Sub-Assembly Industrial Zone Jiading Shaghai China
TEL : 86-21-69576305, 69576306 FAX : 86-21-69576091, 69576093

SUNSTAR MACHINERY GUANG DONG BRANCH (CHINA)

Luosha Daxia 12TH Floor 170 Dong Xing-Road, Dong Guan
Shicheng Qu, Guang Dong, China
TEL : 86-769-249-1610 FAX : 86-769-234-4042

SUNSTAR MACHINERY FUJIAN BRANCH (CHINA)

504, Agricultural Bank Building Shishi Fujian, China
TEL : 86-595-859-8871 FAX : 86-595-859-8872

SUNSTAR MACHINERY QINGDAO BRANCH (CHINA)

Chengyangqu Liutingzhen Chongyanglu Shoufeizhan
Beiduan Shangpinlou Qingdao Shandong, China
TEL : 86-532-482-2236, 86-532-481-1262 FAX : 86-532-481-1262

SUNSTAR MACHINERY JAKARTA BRANCH

JL. Pelepah Indah Raya Bloc LC 2/2 Kelapa Gading Permai
Jakarta(14250) Indonesia
TEL : 62-21-450-2143, 62-21-4584-0752 FAX : 62-21-4584-0214

SUNSTAR MACHINERY HOCHIMINH BRANCH (VIETNAM)

#E23 Nguyen Thai Binh ST. W. 12 Tan Binh District,
Hochiminh City, Vietnam
TEL : 84-8-811-4141 FAX : 84-8-811-4588

SUNSTAR MACHINERY HANOI BRANCH (VIETNAM)

19 Son Tay. W. Dien Bien Ba Dinh Dist., Hanoi, Vietnam
TEL : 84-4-734-0268 FAX : 84-4-734-0278

WEB-SITE

<http://www.sunstar.co.kr>

E-MAIL

sunstar@sunstar.co.kr
swf@sunstar.co.kr
fortuna@sunstar.co.kr

ШВЕЙПРОМ

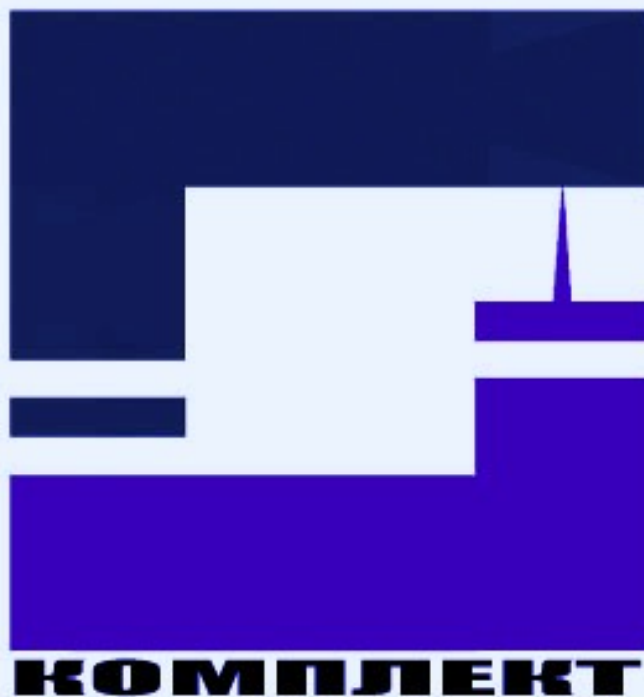
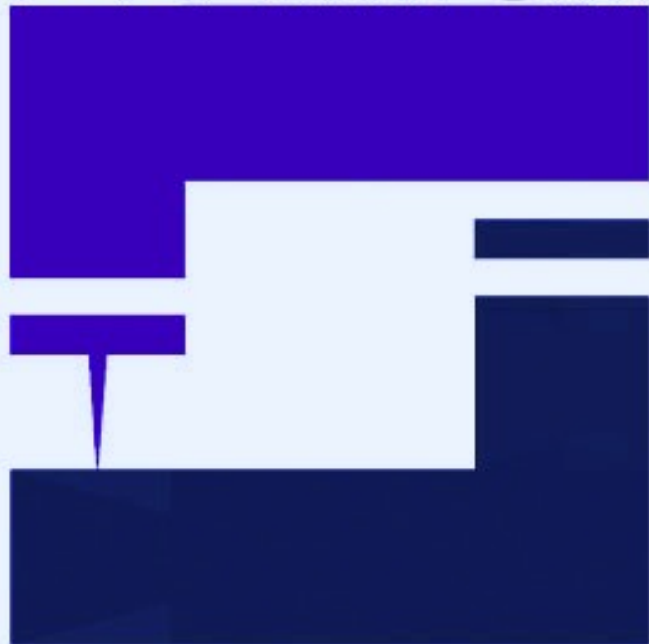

КОМПЛЕКТ

По вопросам приобретения или с целью консультации
вы можете обращаться по телефону: (499)259 2598
или по e-mail

Также предлагаем вам посетить
наш информационный сайт