

ILLUSTRATED PARTS MANUAL
ILLUSTRIERTES TEILEVERZEICHNIS

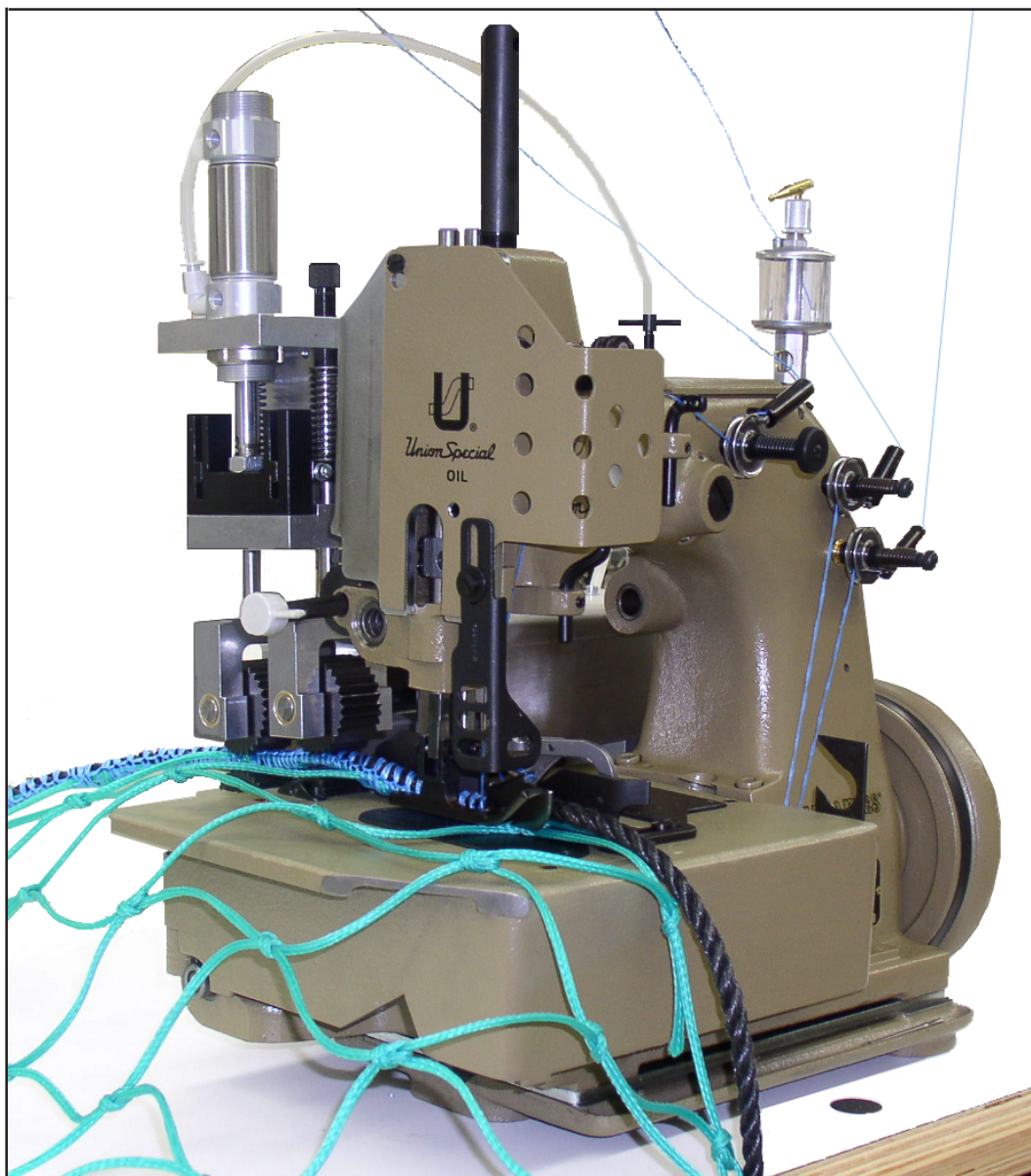

MANUAL NO. / KATALOG NR. G234CZ
FOR STYLES / FÜR TYPEN
81500CZ3374A, 81500CZ3374B

Данная информация
для Вас предоставлена
ООО «ШВЕЙПРОМКОМПЛЕКТ»
Тел./факс: (499) 7951613, тел.: (495) 7260838
www.shveiprom.com
7260838@mail.ru

SUPPLEMENT TO MANUAL NO. G234
ZUSATZ ZUM KATALOG NR. G234

APPLICATION OF THIS MANUAL

This manual is a supplement to the manual No. G234 and should be used in conjunction therewith.

OBSERVE THE SAFETY RULES IN MANUAL NO. G234!



Only the parts found on Styles 81500CZ3374A and 81500CZ3374B are illustrated which are different from those of Style 81500C. INSTALLATION, LUBRICATION, NEEDLES, OPERATING INSTRUCTIONS, MAINTENANCE and INSTRUCTIONS FOR MECHANICS are the same as described in manual No. G234 for Style 81500C.

HINWEISE FÜR DIE BENÜTZUNG DIESES KATALOGS

Dieser Katalog ist ein Zusatz zum Katalog Nr. G234 und muß in Verbindung mit diesem verwendet werden.



BEACHTEN SIE DIE SICHERHEITSHINWEISE IM KATALOG NR. G234!

Es sind nur die Teile für die Maschinen 85100CZ3374A und 81500CZ3374B abgebildet, die sich von denen für die Maschinen 81500C unterscheiden. AUFSTELLUNG, ÖLEN, NADELN, BEDIENUNGSANLEITUNG, WARTUNG und MECHANIKERANLEITUNG sind gleich wie im Katalog Nr. G234 für die Maschine 81500C beschrieben.

Subject to change without notice / Änderungen vorbehalten

G234CZ 04-05
Printed in Germany
All rights reserved

3rd. Edition / 3. Ausgabe
© Union Special GmbH 2005
Alle Rechte vorbehalten

IDENTIFICATION OF MACHINES

Each UNION SPECIAL 81500 series machine is identified by a style number, which is stamped on the style plate affixed to the right front of machine. Serial number is stamped into bed casting at the right front base of machine.

STYLES OF MACHINE

81500CZ3374A: Single Needle, Three Thread Overedging Sewing Machine for attaching ropes from 5/64 inch to 15/32 inch (4 - 12 mm) - depending on the thickness of the net and size of knots - as border or tensioning rope to nets used for sports, protection or safety.

Maximum Speed: 1200 stitches / min.,
depending on fabric and
sewing operation

Recommended operating speed: 950 stitches / min.

Stitch Range: 2 - 5 SPI (4 - 12 mm)

Standard Setting: 2.5 SPI (10 mm)

Sewing Capacity: 3/64 - 5/8 inch (2 - 10 mm)

Standard Needle: 9853GA300/120

On Request: Needle with large ball point
9844GAN300/120,
9844GAN400/156

Needle Stroke: 2 51/64 inch (71 mm)

Handwheel pitch dia = 5 27/32 inch (150 mm)

Needle Thread: Net Yarn 210/24 or 210/3
PP Yarn, 4000 Denier

Looper Thread: Net Yarn 210/24 or 210/30
PP Yarn, 4000 Denier

Feed: Intermittent stepper twin puller,
two driven upper and one driven lower roller. Roller
pitch 5 mm.

Required Installation: UN280G132

Sewing table with clutch motor
Motor pulley pitch dia = 3 15/16 inch (100 mm)

For nets sewn parallel to the meshes, no feed dog is used and the throat plate has no slots (Standard version).

For nets sewn diagonal to the meshes a feed dog with matching throat plate is included.

Max. SPI 2.5 (10 mm).

For joining nets larger than 45 mm mesh width.

81500CZ3374B: Same as 81500CZ3374A but for attaching ropes from 25/64 inch to 5/8 inch (10 - 16 mm) - depending on the thickness of the net and size of knots.

Sewing capacity: 5/64 - 15/32 inch (2 - 12 mm).

Performance tests necessary for both machines.

Stitch Type / Seam Type

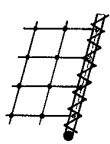

Net parallel
to rope

Stitch Type 504
Seam Type EFd-1

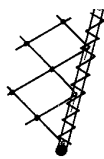

Net diagonal
to rope

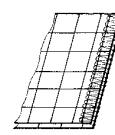
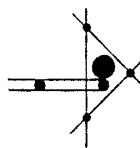

Nets joined
parallel

Stitch Type 504
Seam Type Ssa-1

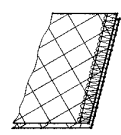

Nets joined
diagonal

BEZEICHNUNG DER MASCHINEN

Jede UNION SPECIAL 81500 Maschine hat eine in das Typenschild eingeprägte Typennummer, das rechts vorne am Gehäuse befestigt ist. Die Seriennummer ist in das Gußgehäuse rechts vorne im Sockel der Maschine eingeprägt.

MASCHINENTYPEN

81500CZ3374A: Einnadel-Dreifaden-Überwendlich-Nähmaschine zum Annähen von Seilen mit einem Durchmesser von 4 bis 12 mm (abhängig von Netzdicke und Größe der Knoten) als Randabschluß oder als Spannseil an Netze, besonders an Sport-, Schutz- und Sicherheitsnetzen.

Maximale Drehzahl: 1200 Stiche / min.,
je nach Material und
Nähoperation

Empfohlene Betriebsdrehzahl: 950 Stiche / min.

Stichlänge: 4 - 12 mm

Standardstichlänge: 10 mm

Nähgutdurchgang: 2 - 10 mm

Standardnadel: 9853GA300/120

Auf Anfrage: Nadel mit großer Kugelspitze
9844GAN300/120,
9844GAN400/156

Nadelhub: 71 mm

Handrad-Durchmesser = 150 mm

Nadelfaden: Netzgarn 210/24 oder 210/30
PP-Garn, 4000 Denier

Greiferfaden: Netzgarn 210/24 oder 210/30
PP-Garn, 4000 Denier

Transport: Intermittierender Schritt-Doppel-
puller, zwei obere und eine untere Rolle angetrieben,
Rollenzahlteilung 5 mm.

Erforderlicher Arbeitsplatz: UN280G132

Nähtisch mit Kupplungsmotor
Motor-Scheibendurchmesser = 100 mm

Für Netze, an denen parallel zu den Maschen genäht wird, wird in der Nähmaschine kein Transporteur verwendet; die Stichplatte ist ohne Transporteurschlitz (Standardausführung). Für Netze, an denen diagonal zu den Maschen genäht wird, wird ein Transporteur mit passender Stichplatte verwendet (beigepackt), Stichlänge max. 10 mm.

Zum Zusammennähen von Netzen ab 45 mm Maschenweite.

81500CZ3374B: Wie 81500CZ3374A, jedoch zum Annähen von Seilen von 10 - 16 mm, abhängig von Netzdicke und Größe der Knoten.

Nähgutdurchgang: 2 - 12 mm.

Nähversuche für beide Maschinen erforderlich.

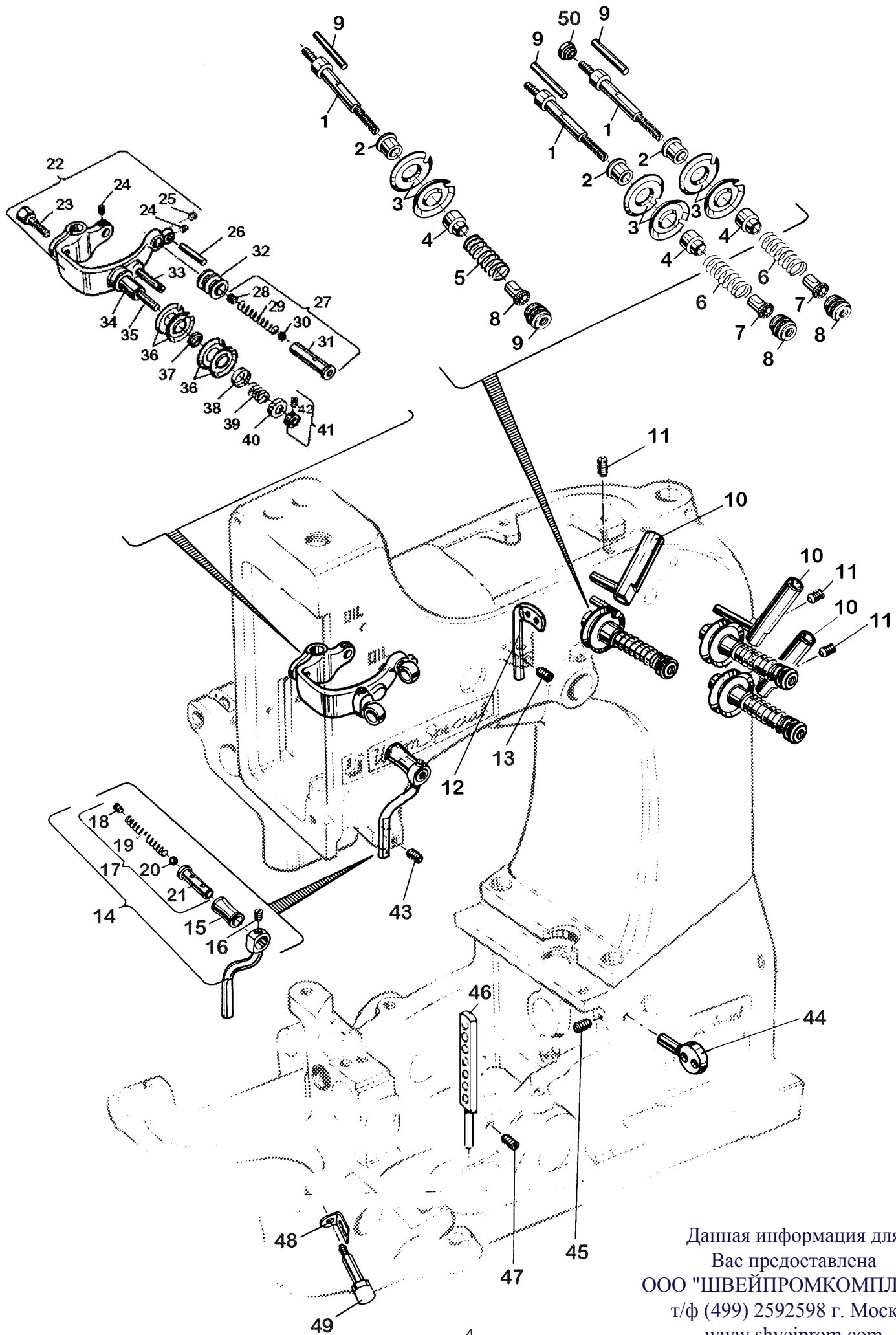

Данная информация для
 Вас предоставлена
 ООО "ШВЕЙПРОМКОМПЛЕКТ"
 т/ф (499) 2592598 г. Москва
www.shveiprom.com
2592598@mail.ru

THREAD TENSION AND GUIDE PARTS
FADENSPANNUNGEN UND FADENFÜHRUNGSTEILE

<u>Ref. No.</u> <u>Pos. No.</u>	<u>Part No.</u> <u>Teil Nr.</u>	<u>Description</u>	<u>Beschreibung</u>	<u>Amt. Req.</u> <u>Anzahl</u>
1	HS106	Tension Post	Spannungsbolzen	3
2	80669B	Tension Post Ferrule	Hülse für Spannungsbolzen	3
3	80676A	Tension Disc	Spannungsscheibe	6
4	HA1349	Tension Sleeve	Federhülse	3
5	HS110A	Spring for Needle Thread Tension	Feder für Nadelfadenspannung	1
6	110-2	Spring for Looper Thread Tension	Feder für Greiferfadenspannung	2
7	107	Tension Spring Ferrule	Spannungsfeder-Hülse	3
8	108	Tension Nut	Spannungsmutter	3
9	80667	Pin for Tension Discs	Stift für Spannungsscheiben	3
10	81256A	Thread Sleeve	Fadenhülse	3
11	22560B	Set Screw	Gewindestift	3
12	80858AX	Needle Thread Guide	Nadelfadenführung	1
13	22894AD	Set Screw	Gewindestift	1
14	80665D	Needle Thread Take-up Roller Assm.	Nadelfadenabzugsrolle, komplett	1
15	80668	Take-up Roller	Abzugsrolle	1
16	88	Set Screw	Gewindestift	1
17	HS53B	Roller Stud Assembly	Rollenbolzen, komplett	1
18	22560	Set Screw	Gewindestift	1
19	HA1286B	Spring	Feder	1
20	12964C	Spring Ball	Federkugel	1
21	81086G	Roller Stud	Rollenbolzen	1
22	80759	Needle Bar Connection	Nadelstangenmitnehmer	1
23	BP108	Hex. Head Cap Screw	Sechskantschraube	1
24	22894AY	Set Screw	Gewindestift	2
25	22894W	Set Screw	Gewindestift	1
26	80655D	Thread Guide Pin	Fadenführungsstift	1
27	HS52B	Roller Stud Assembly	Rollenbolzen komplett	1
28	22560	Set Screw	Gewindestift	1
29	HA1286B	Spring	Feder	1
30	12964C	Spring Ball	Federkugel	1
31	81086C	Roller Stud	Rollenbolzen	1
32	81293	Thread Guide Roller	Fadenführungsrolle	1
33	92132	Shank Screw	Zapfenschraube	1
34	80669A	Tension Post Ferrule	Hülse für Spannungsbolzen	1
35	81246	Tension Post	Spannungsbolzen	1
36	80676	Tension Disc	Spannungsscheibe	4
37	81294	Spacer Ring	Distanzring	1
38	HA58C	Spring Ferrule	Federhülse	1
39	HA58F	Spring	Feder	1
40	HA58D	Spring Ferrule	Federhülse	1
41	21111	Collar	Stelling	1
42	22743	Set Screw	Gewindestift	1
43	22894AD	Set Screw	Gewindestift	1
44	81254A	Eyelet for looper threads	Fadenführung für Greiferfäden	1
45	22894AD	Set Screw	Gewindestift	1
46	81287A	Looper Thread Guide	Greiferfadenführung	1
47	88	Set Screw	Gewindestift	1
48	81350D	Looper Thread Guide	Greiferfadenführung	1
49	80696A	Stud	Bolzen	1
50	99623A	Spacer for lower looper thread tension post	Distanzbuchse für unteren Greiferfaden-Spannungsbolzen	1

Данная информация для
Вас предоставлена
ООО "ШВЕЙПРОМКОМПЛЕКТ"
т/ф (499) 2592598 г. Москва
www.shveiprom.com
2592598@mail.ru

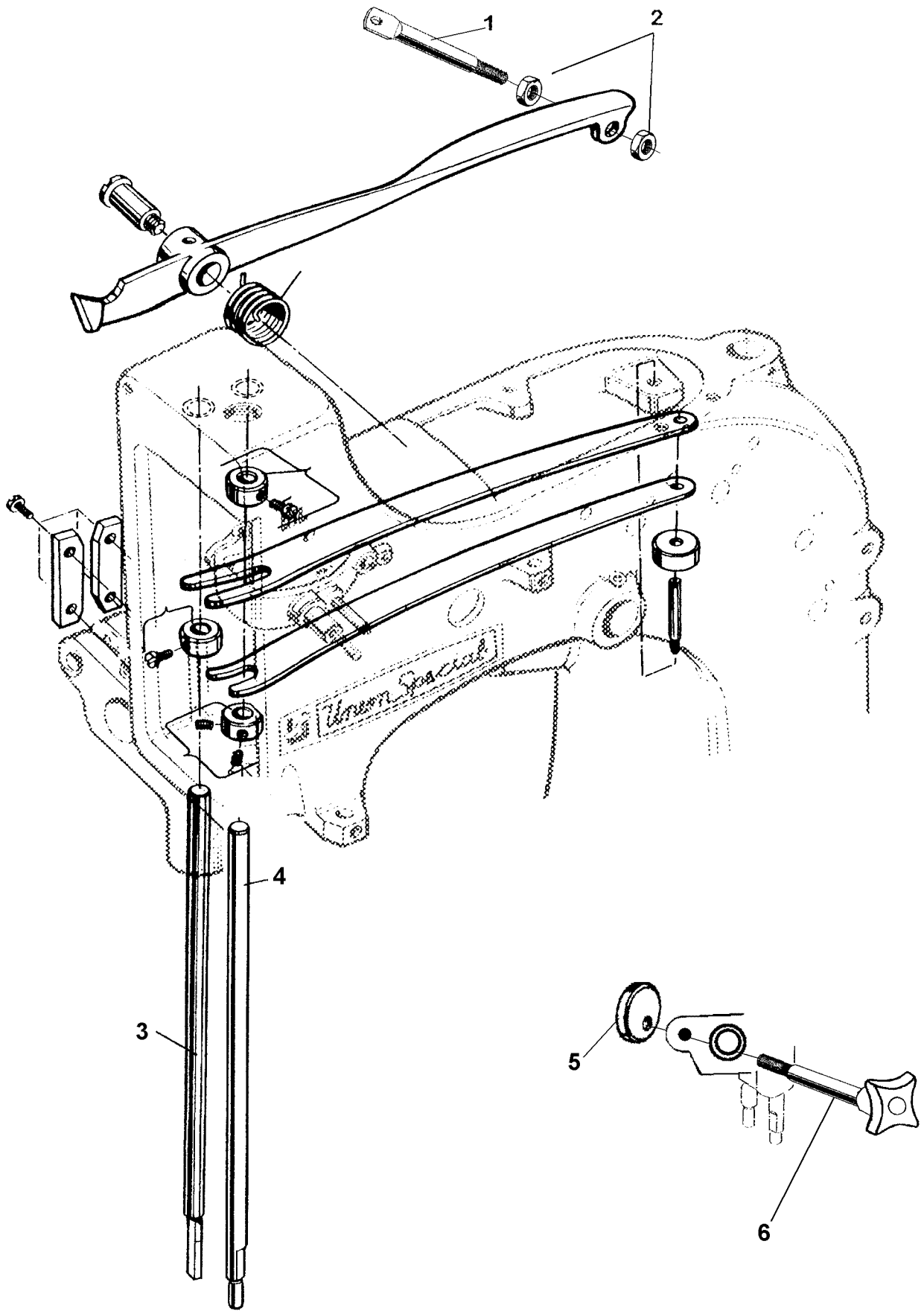

PRESSER BARS AND PRESSERFOOT LIFTER
DRÜCKERUSSSTANGEN UND DRÜCKFUSSLIFTERHEBEL

<u>Ref. No.</u> <u>Pos. No.</u>	<u>Part No.</u> <u>Teil Nr.</u>	<u>Description</u>	<u>Beschreibung</u>	<u>Amt. Req.</u> <u>Anzahl</u>
1	35780B	Lifter Lever Extension	Lifterverlängerung	1
2	258	Nut	Mutter	2
3	80760A	Presser Bar, left	Drückerfußstange, links	1
4	80661B	Presser Bar, right	Drückerfußstange, rechts	1
5	81567B	Eccentric Disc	Exzentrerscheibe	1
6	81567A	Handle Screw	Griffschraube	1

Данная информация для
Вас предоставлена
ООО "ШВЕЙПРОМКОМПЛЕКТ"
т/ф (499) 2592598 г. Москва
www.shveiprom.com
2592598@mail.ru

81500 CZ-3374 A/B

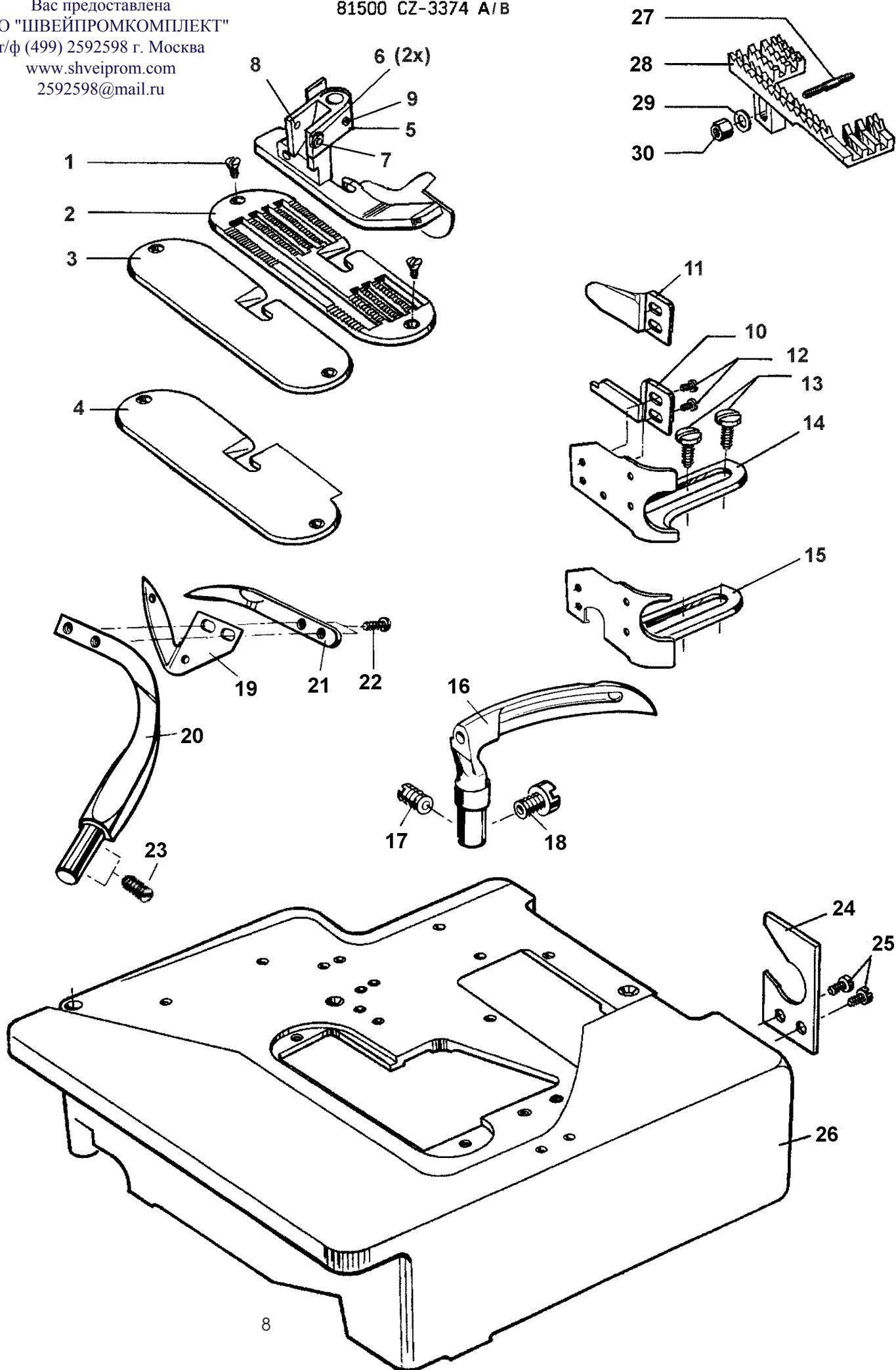

SEWING PARTS AND CLOTH PLATE
NÄHTEILE UND STOFFPLATTE

<u>Ref. No.</u> <u>Pos. No.</u>	<u>Part No.</u> <u>Teil Nr.</u>	<u>Description</u>	<u>Beschreibung</u>	<u>Amt. Req.</u> <u>Anzahl</u>
1	78057	Screw	Linsensenkschraube	2
2	81524B	Throat Plate	Stichplatte	1
3	81524L	Throat Plate for 3374A	Stichplatte ohne Transportschlitz für 3374A	1
4	81524LA	Throat Plate for 3374B	Stichplatte ohne Transportschlitz für 3374B	1
5	81520LA	Presser Foot	Drückerfuß	1
6	12934A	Nut	Sechskantmutter	2
7	89	Screw	Gewindestift J2x4,8	1
8	22560A	Screw	Gewindestift J2x8,7	1
9	22894AD	Screw	Gewindestift Q2x6,4	1
10	81503M	Cloth Guide Tongue for 3374A	Stoffführungszunge für 3374A	1
11	81503MA	Cloth Guide Tongue for 3374B	Stoffführungszunge für 3374B	1
12	HS24C	Screw	Zylinderschraube	2
13	22514	Screw	Zylinderschraube	2
14	81303FL	Edge Guide for 3374A	Stoffkantenführung für 3374A	1
15	81303FLA	Edge Guide for 3374B	Stoffkantenführung für 3374B	1
16	81508	Looper, lower	Greifer, unten	1
17	74F	Set Screw	Gewindestift	1
18	99240	Screw	Schraube	1
19	81507C	Looper, upper	Greifer, oben	1
20	81507A	Looper Shank	Greiferschaft	1
21	81310	Thread Hook, marked "GP"	Fadenhaken, gekennzeichnet "GP"	1
22	22593A	Screw	Schraube	2
23	74F	Set Screw	Gewindestift	1
24	81503N	Rope Guide	Seilführung	1
25	94	Screw	Zylinderschraube	2
26	81501LP	Cloth Plate	Stoffplatte	1
27	22686C	Screw	Gewindestift, Innensechskant	1
28	81505L	Feed Dog	Transporteur	1
29	69H	Washer	Unterlagscheibe	1
30	51487	Nut	Sechskantmutter	1

**Top Rollers
Rolleneinheit oben**

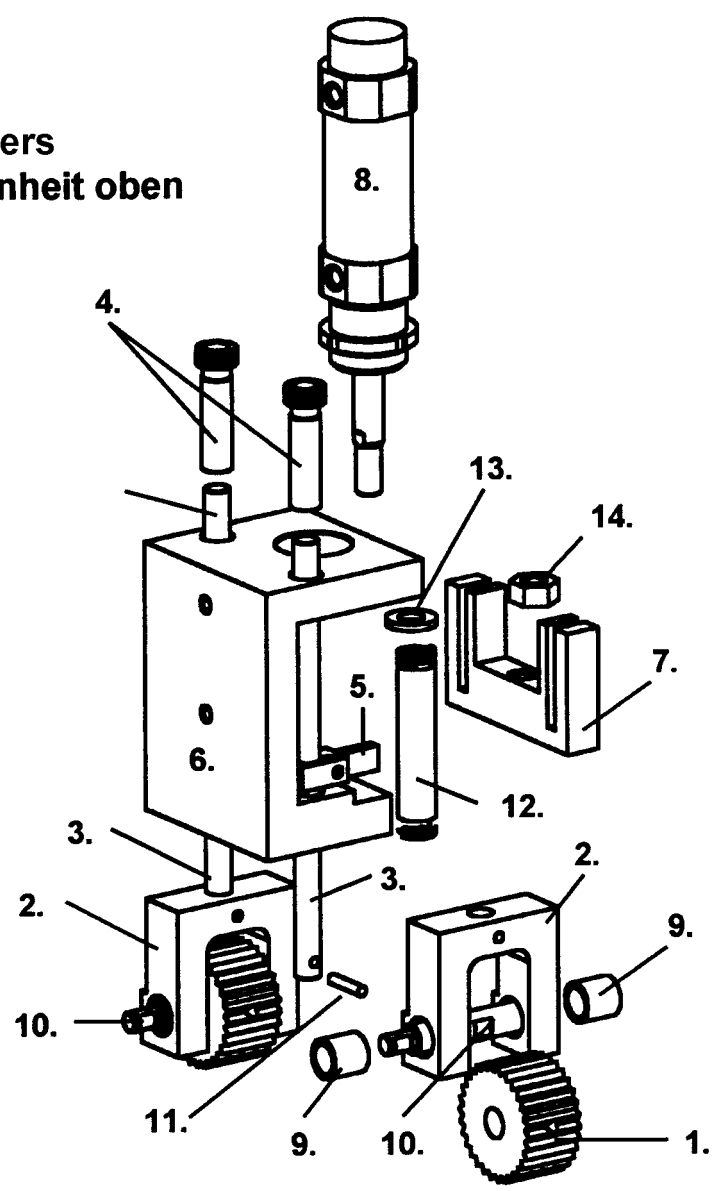

STEPPER PULLER COMPLETE WITH PNEUMATIC CONTROL WD99706A
SCHRITTPULLER KOMPLETT MIT PNEUMATISCHER STEUERUNG WD99706A

<u>Ref. No.</u> <u>Pos. No.</u>	<u>Part No.</u> <u>Teil Nr.</u>	<u>Description</u>	<u>Beschreibung</u>	<u>Amt. Req.</u> <u>Anzahl</u>
	WD99706A	Stepper Puller complete with Pneumatic Control	Schrittpuller komplett mit pneumatischer Steuerung	1
1.	22562A	Screw	Zylinderschraube	4
2.	22874	Screw	Zylinderschraube	2
3.	99683M	Filter Regulator complete	Filderdruckminderer komplett	1
4.	999-126	Coupling	Schraubanschlussstück 1/8 -6/4	1
5.	999-127	Corner Connection	Eck-Anschlussstück	1
6.	G29912	Knee Presser Valve	Pneumatikventil für Kniebetätigung	1
7.	WD99706	Stepper Puller (see parts list below)	Schrittpuller (siehe Teileliste unten)	1

Данная информация для
 Вас предоставлена
 ООО "ШВЕЙПРОМКОМПЛЕКТ"
 т/ф (499) 2592598 г. Москва
 www.shveiprom.com
 2592598@mail.ru

STEPPER PULLER WD99706
SCHRITTPULLER WD99706

<u>Ref. No.</u> <u>Pos. No.</u>	<u>Part No.</u> <u>Teil Nr.</u>	<u>Description</u>	<u>Beschreibung</u>	<u>Amt. Req.</u> <u>Anzahl</u>
	WD99706	Stepper Puller	Schrittpuller	1
1.	WD7001	Crimping Roller	Pullerrad	1
2.	WD7002	Roller Yoke	Joch oben	2
3.	WD7003	Yoke Shaft	Pullerstange	2
4.	WD7004	Presser Bar Regulating Screw	Hohlschraube	2
5.	WD7005	Connection and Guide	Mitnehmer Pullerstange	1
6.	WD7006	Main Roller Bracket	Aufnahmeplatte	1
7.	WD7007	Lever Support	Rollenlifter	1
8.	WDC75E-32-25	Cylinder	Zylinder	1
9.	WDSB121616	Bronze Bushing	Sinterbronzelager	2
10.	WD5003	Shaff for Crimping Roller	Welle Pullerrad	1
11.	96500B	Pin	Zylinderstift 4Mx6x20	1
12.	WDD232R	Roller Pressure Spring	Druckfeder	1
13.	95910D	Washer	Unterlegscheibe DIN1441 D10	1
14.	95252	Nut	Sechskantmutter M10 DIN934	1
15.	95400	Screw	Sechskantzylinderschraube M6X20 DIN912	2
16.	95406A	Screw	Sechskantzylinderschraube M4X16 DIN912	1
17.	WDKQ2L06-01S	Fitting	Verschraubung	1
18.	WDAN103-01	Muffler	Schalldämpfer	1

Bottom Roller
Rolle unten

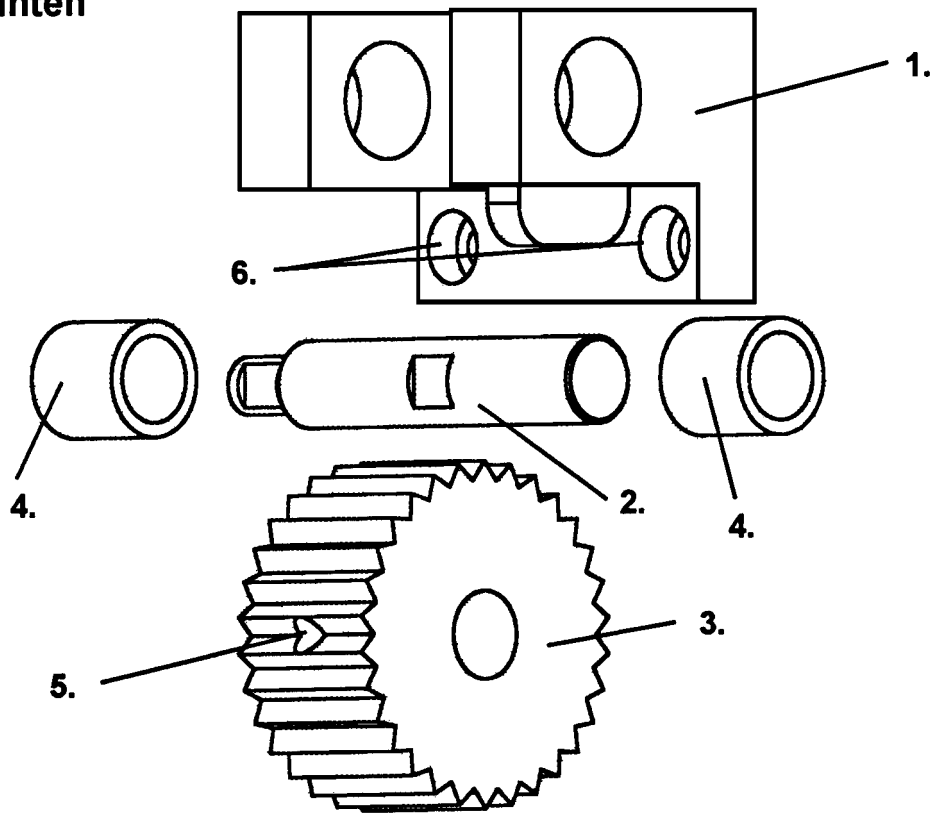

Roller small
Rolle klein

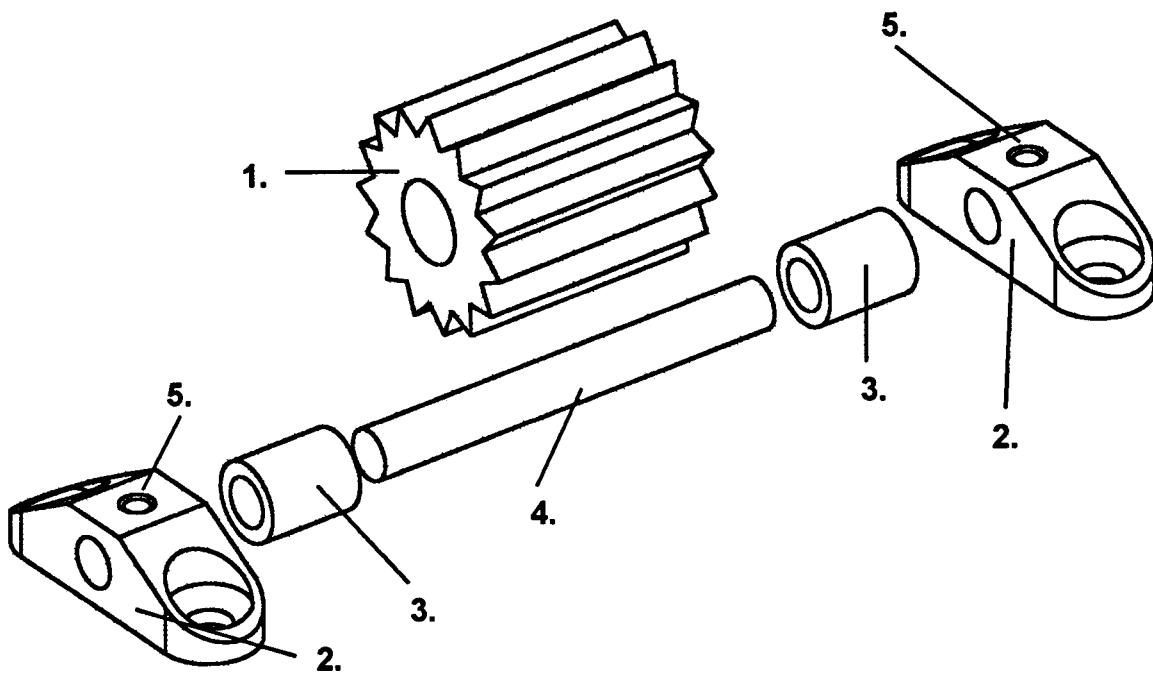

STEPPER PULLER WD99706
SCHRITTPULLER WD99706

<u>Ref. No.</u> <u>Pos. No.</u>	<u>Part No.</u> <u>Teil Nr.</u>	<u>Description</u>	<u>Beschreibung</u>	<u>Amt. Req.</u> <u>Anzahl</u>
1.	WD5002	Roller Yoke	Joch unten	1
2.	WD5003	Roller Shaft	Welle Pullerrad	1
3.	WD7001	Crimping Roller	Pullerrad groß	1
4.	WDSB121616	Bronze Bushing	Sinterbronzelager	2
5.	95515D	Screw	Gewindestift M6X12 DIN913	1
6.	95412D	Screw	Zylinderschraube M5X15 DIN912	2

<u>Ref. No.</u> <u>Pos. No.</u>	<u>Part No.</u> <u>Teil Nr.</u>	<u>Description</u>	<u>Beschreibung</u>	<u>Amt. Req.</u> <u>Anzahl</u>
1.	WD6001	Crimping Roller	Pullerrad klein	1
2.	WD6002	Bottom Roller Bearing	Lager für Rolle klein	2
3.	WDSB5810	Bronze Bushing	Sinterbronzelager	2
4.	96514E	Pin	Zylinderstift 5 _{mm} x45 DIN6325	1
5.	95515F	Screw	Gewindestift M3X2 DIN913	2

Данная информация для
Вас предоставлена
ООО "ШВЕЙПРОМКОМПЛЕКТ"
т/ф (499) 2592598 г. Москва
www.shveiprom.com
2592598@mail.ru

**Clutch
Kupplungseinheit**

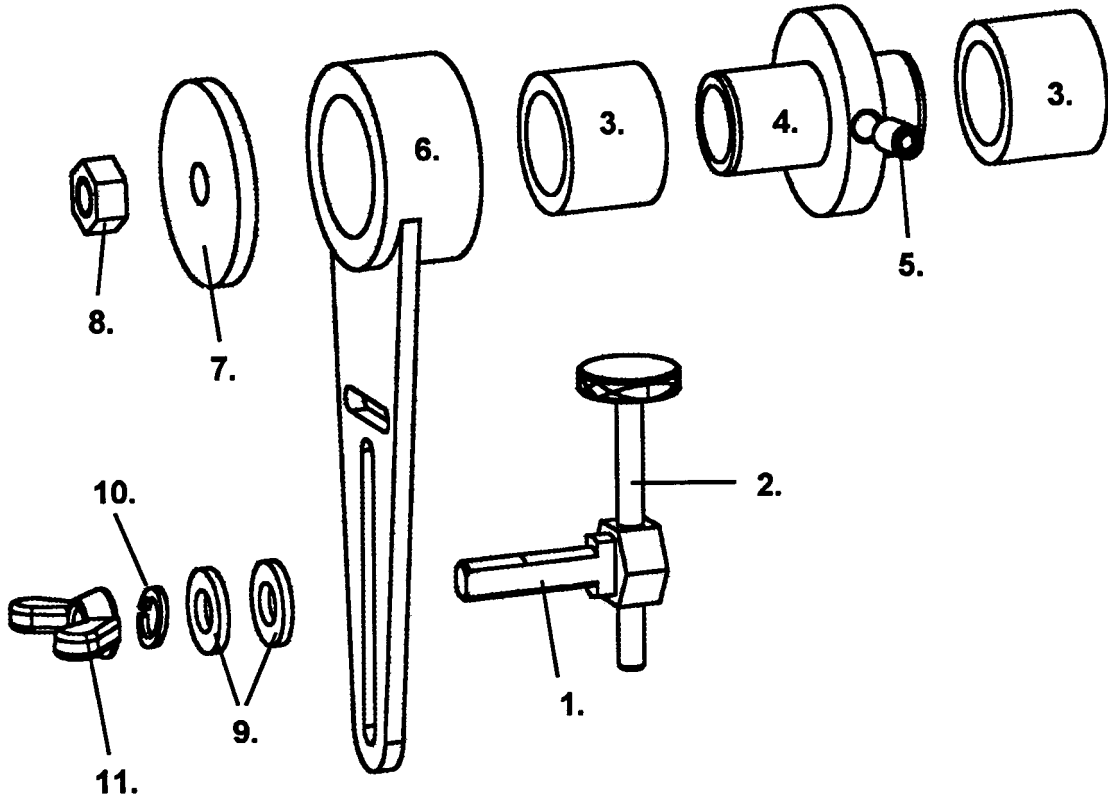

**Coupling
Verbindungseinheit**

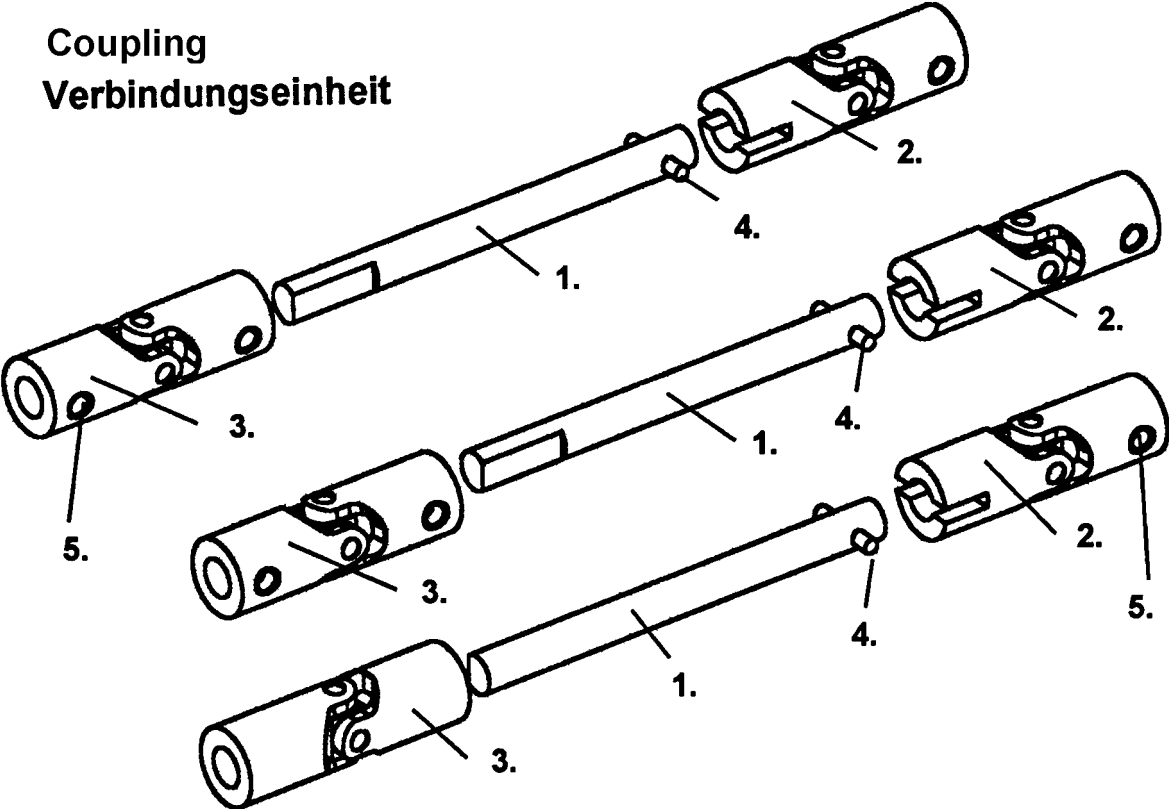

STEPPER PULLER WD99706
SCHRITTPULLER WD99706

<u>Ref. No.</u> <u>Pos. No.</u>	<u>Part No.</u> <u>Teil Nr.</u>	<u>Description</u>	<u>Beschreibung</u>	<u>Amt. Req.</u> <u>Anzahl</u>
1.	WD2001	Bolt	Bolzen	1
2.	WD2002	Adjusting Screw	Stellschraube	1
3.	WDHF1616	Bushing	Buchse	2
4.	WD2004	Clutch Holder	Aufnahme Kupplungslager	1
5.	95515C	Screw	Gewindestift M5x8 DIN913	1
6.	WD2100	Clutch Lever	Kupplungshebel	1
7.	WD2003	Washer	Scheibe	1
8.	95250	Nut	Sechskantmutter M6 DIN934	1
9.	95910C	Washer	Unterlegscheibe 6,4 DIN125	2
10.	96020	Spring Ring	Federring 6 DIN127	1
11.	95901A	Fly Nut	Flügelmutter M6 DIN315 verzinkt	1

<u>Ref. No.</u> <u>Pos. No.</u>	<u>Part No.</u> <u>Teil Nr.</u>	<u>Description</u>	<u>Beschreibung</u>	<u>Amt. Req.</u> <u>Anzahl</u>
1.	WD4001	Drive Shaft	Welle	3
2.	WD4200	Universal Coupling	Gelenk mit Schlitz	3
3.	WD4100	Universal Coupling	Gelenk	3
4.	96500A	Pin	Zylinderstift 3 _{m6} x16 DIN6325	3
5.	95515E	Screw	Gewindestift M5X5 DIN913	6

Данная информация для
Вас предоставлена
ООО "ШВЕЙПРОМКОМПЛЕКТ"
т/ф (499) 2592598 г. Москва
www.shveiprom.com
2592598@mail.ru

Gear Box
Getriebekasten

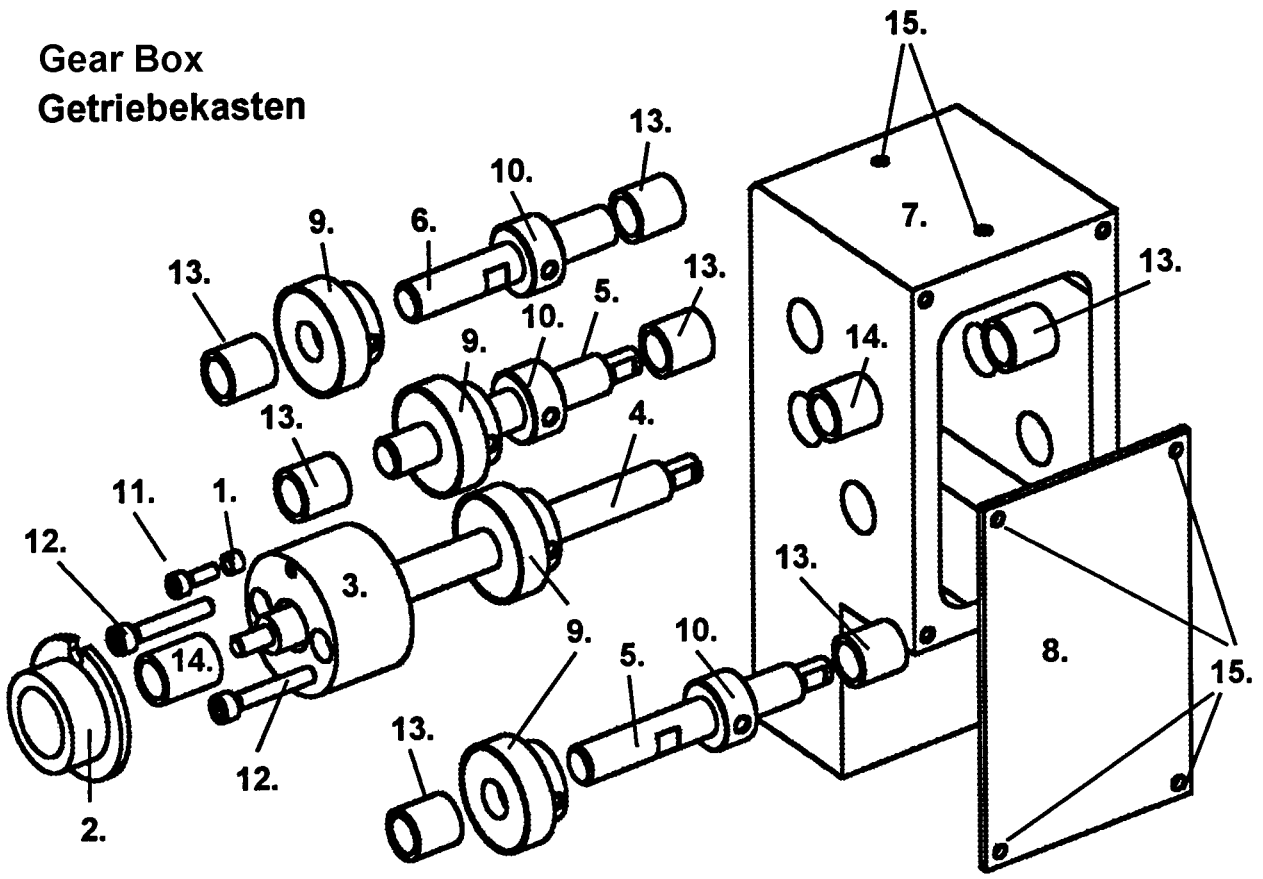

STEPPER PULLER WD99706
SCHRITTPULLER WD99706

<u>Ref. No.</u> <u>Pos. No.</u>	<u>Part No.</u> <u>Teil Nr.</u>	<u>Description</u>	<u>Beschreibung</u>	<u>Amt. Req.</u> <u>Anzahl</u>
1.	WD3001	Clutch Anti Rotation Stop	Anschlag	1
2.	WD3002	Clutch Flange	Kupplungsflansch	1
3.	WD3003	Gearbox Clutch Mounting Block	Kupplungslager	1
4.	WD3004	Jockey Gear Shaft, long	Getriebewelle, lang	1
5.	WD3005	Jockey Gear Shaft	Getriebewelle	2
6.	WD3006	Jockey Gear Shaft, short	Getriebewelle, kurz	1
7.	WD3007	Gearbox	Getriebekasten	1
8.	WD3008	Gearbox Cover	Deckel	1
9.	WD3009	Gear Wheel	Zahnrad	4
10.	WD705	Collar	Stellring	3
11.	95409D	Screw	Sechskantzylinderschraube M4x12 DIN912	1
12.	95422	Screw	Sechskantzylinderschraube M5x30 DIN912	2
13.	WDSB121616	Bronze Bushing	Sinterbronzelager	7
14.	WDSB121620	Bronze Bearing	Sinterbronzelager	1
15.	95409B	Screw	Sechskantzylinderschraube M4x8 DIN912	6

Drive Unit
Antriebseinheit

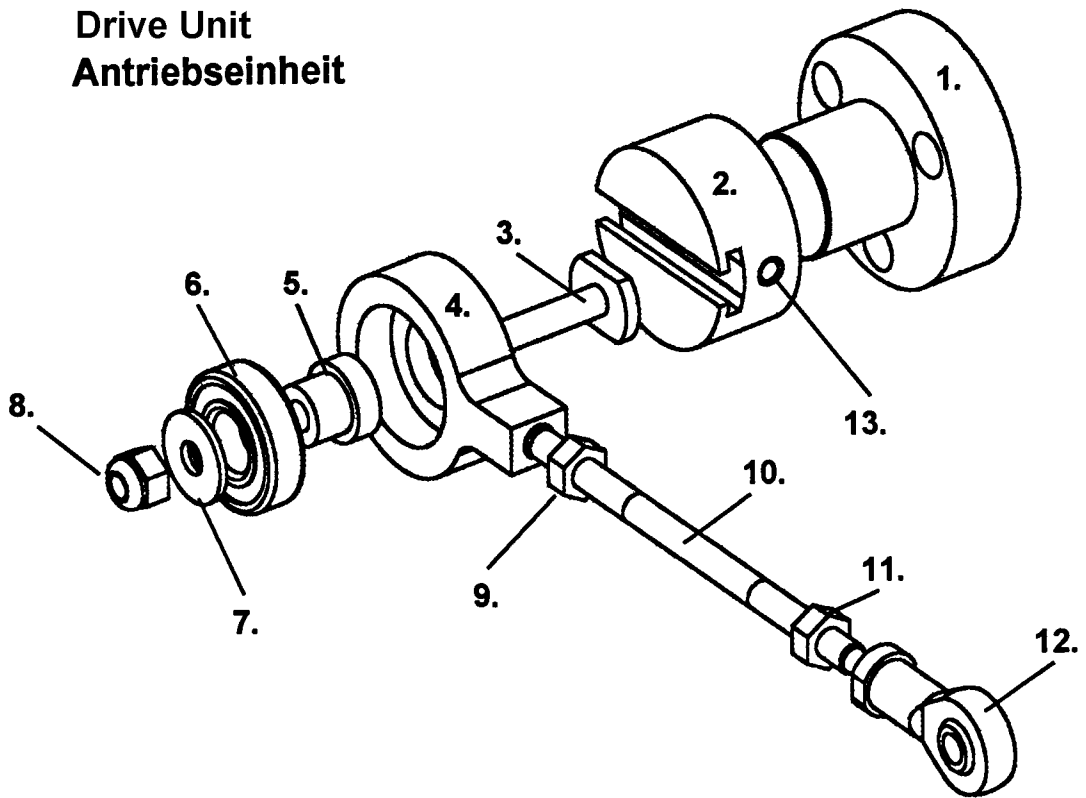

STEPPER PULLER WD99706
SCHRITTPULLER WD99706

<u>Ref. No.</u> <u>Pos. No.</u>	<u>Part No.</u> <u>Teil Nr.</u>	<u>Description</u>	<u>Beschreibung</u>	<u>Amt. Req.</u> <u>Anzahl</u>
1.	WD1001	Pulley Adapter	Kupplungsflansch	1
2.	WD1010	Handwheel Real Spigot Sleeve	Muffe für Handradadapter	1
3.	WD1011	T-Bolt	T-Bolzen	1
4.	WD1004	Bearing Housing	Lagergehäuse	1
5.	WD1005	Bushing	Buchse	1
6.	WDSKF6001-2Z	Bearing	Rillenkugellager	1
7.	96124	Washer	Unterlegscheibe A6,4 DIN9021, verz.	1
8.	95265	Nut	Sechskantmutter M6 DIN982, selbstsi.	1
9.	95250L	Nut	Sechskantmutter M6 DIN934, links ver.	1
10.	WD1007	Connecting Rod	Verbindungsstange	1
11.	95250	Nut	Sechskantmutter M6 DIN934	1
12.	WDKJ6DM6	Ball End	Gelenkkopf	1
13.	95515C	Screw	Gewindestift M5x8 DIN913	1

**Attaching Parts
Anbauteile**

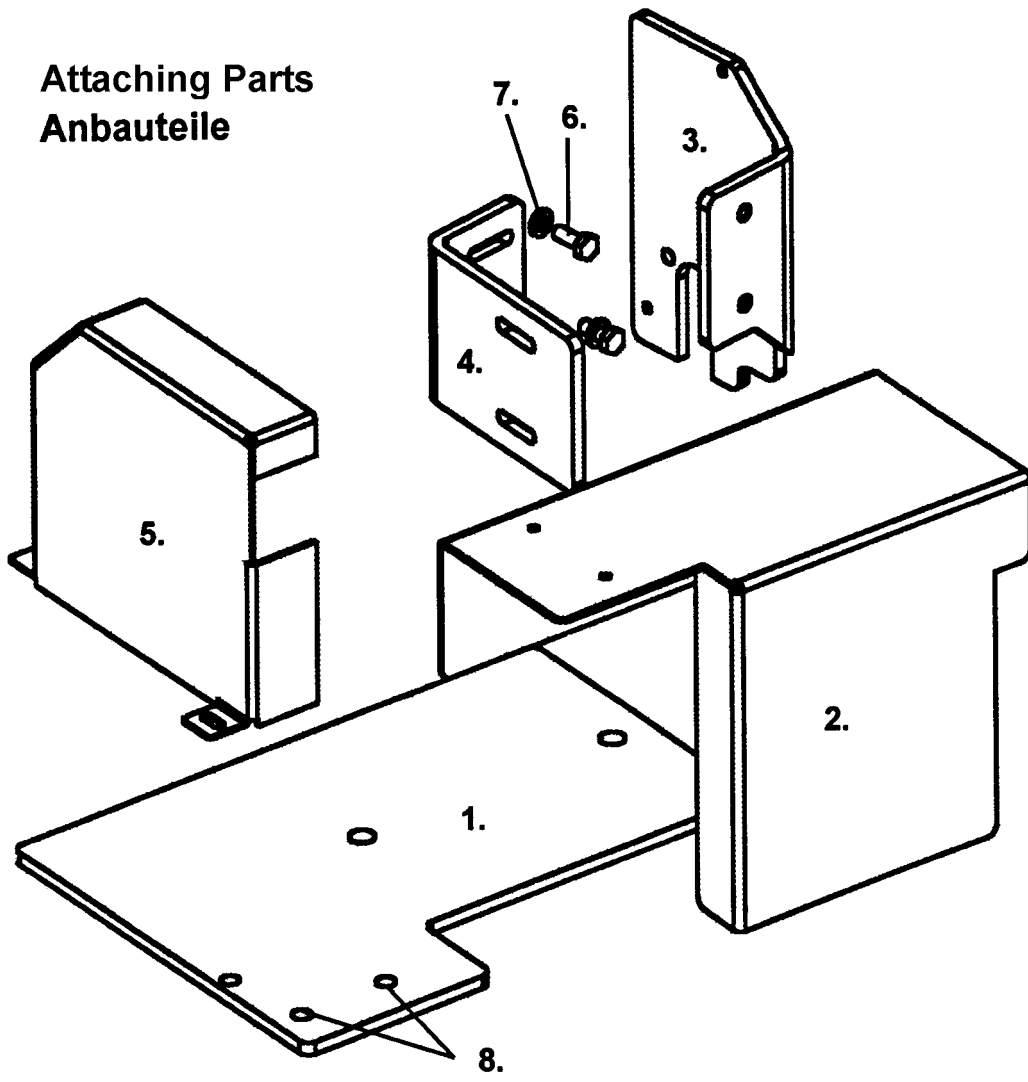

STEPPER PULLER WD99706
SCHRITTPULLER WD99706

<u>Ref. No.</u> <u>Pos. No.</u>	<u>Part No.</u> <u>Teil Nr.</u>	<u>Description</u>	<u>Beschreibung</u>	<u>Amt. Req.</u> <u>Anzahl</u>
1.	WD8001	Base Plate	Grundplatte	1
2.	WD8002	Shaft Cover, rear	Abdeckung, hinten	1
3.	WD8003	Face Plate Mounting Bracket	Befestigungswinkel	1
4.	WD8004	Bracket	Haltewinkel	1
5.	WD8005	Belt Cover	Riemenabdeckung	1
6.	95051	Screw	Sechskantschraube M6x16 DIN 933	2
7.	95910C	Washer	Unterlegscheibe 6,4 DIN125	2
8.	95861	Screw	Sechskantzylinderschraube M8X20 DIN912	2

NUMMERICAL INDEX OF PARTS
TEILE INDEX

<u>Part No.</u>	<u>Page</u>	<u>Part No.</u>	<u>Page</u>	<u>Part No.</u>	<u>Page</u>
<u>Teil Nr.</u>	<u>Seite</u>	<u>Teil Nr.</u>	<u>Seite</u>	<u>Teil Nr.</u>	<u>Seite</u>
107 ... 5		81507C ... 9		WD1001 ... 19	
108 ... 5		81508 ... 9		WD1004 ... 19	
110-2 ... 5		81520LA ... 9		WD1005 ... 19	
12934A ... 9		81524B ... 9		WD1007 ... 19	
12964C ... 5		81524L ... 9		WD1010 ... 19	
21111 ... 5		81524LA ... 9		WD1011 ... 19	
22514 ... 9		81567A ... 7		WD2001 ... 15	
22560 ... 5		81567B ... 7		WD2002 ... 15	
22560A ... 9		88 ... 5		WD2003 ... 15	
22560B ... 5		89 ... 9		WD2004 ... 15	
22562A ... 11		92132 ... 5		WD2100 ... 15	
22593A ... 9		94 ... 9		WD3001 ... 17	
22686C ... 9		95051 ... 21		WD3002 ... 17	
22743 ... 5		95250 ... 15, 19		WD3003 ... 17	
22874 ... 11		95250L ... 19		WD3004 ... 17	
22894AD ... 5, 9		95252 ... 11		WD3005 ... 17	
22894AY ... 5		95265 ... 19		WD3006 ... 17	
22894W ... 5		95400 ... 11		WD3007 ... 17	
258 ... 7		95406A ... 11		WD3008 ... 17	
35780B ... 7		95409B ... 17		WD3009 ... 17	
51487 ... 9		95409D ... 17		WD4001 ... 15	
69H ... 9		95412D ... 13		WD4100 ... 15	
74F ... 9		95422 ... 17		WD4200 ... 15	
78057 ... 9		95515C ... 15, 19		WD5002 ... 13	
80655D ... 5		95515D ... 13		WD5003 ... 11, 13	
80661B ... 7		95515E ... 15		WD6001 ... 13	
80665D ... 5		95515F ... 13		WD6002 ... 13	
80667 ... 5		95861 ... 21		WD7001 ... 11, 13	
80668 ... 5		95901A ... 15		WD7002 ... 11	
80669A ... 5		95910C ... 15, 21		WD7003 ... 11	
80669B ... 5		95910D ... 11		WD7004 ... 11	
80676 ... 5		96020 ... 15		WD7005 ... 11	
80676A ... 5		96124 ... 19		WD7006 ... 11	
80696A ... 5		96500A ... 15		WD7007 ... 11	
80759 ... 5		96500B ... 11		WD705 ... 17	
80760A ... 7		96514E ... 13		WD800 ... 21	
80858AX ... 5		99240 ... 9		WD8001 ... 21	
81086C ... 5		99623A ... 5		WD8002 ... 21	
81086G ... 5		99683M ... 11		WD8004 ... 21	
81246 ... 5		999-126 ... 11		WD8005 ... 21	
81254A ... 5		999-127 ... 11		WD99706 ... 11	
81256A ... 5		BP108 ... 5		WD99706A ... 11	
81287A ... 5		G29912 ... 11		WDAN103-01 ... 11	
81293 ... 5		HA1286B ... 5		WDC75E-32-25 ... 11	
81294 ... 5		HA1349 ... 5		WDD232R ... 11	
81303FL ... 9		HA58C ... 5		WDHF1616 ... 15	
81303FLA ... 9		HA58D ... 5		WDKJ6DM6 ... 19	
81310 ... 9		HA58F ... 5		WDKQ2L06-01S ... 11	
81350D ... 5		HS106 ... 5		WDSB121616 ... 11, 13, 17	
81501LP ... 9		HS110A ... 5		WDSB121620 ... 17	
81503M ... 9		HS24C ... 9		WDSB5810 ... 13	
81503MA ... 9		HS52B ... 5		WDSKF6001-2Z ... 19	
81503N ... 9		HS53B ... 5			
81505L ... 9					
81507A ... 9					

Данная информация
для Вас предоставлена
ООО «ШВЕЙПРОМКОМПЛЕКТ»
Тел./факс: (499) 7951613, тел.: (495) 7260838
www.shveiprom.com
7260838@mail.ru

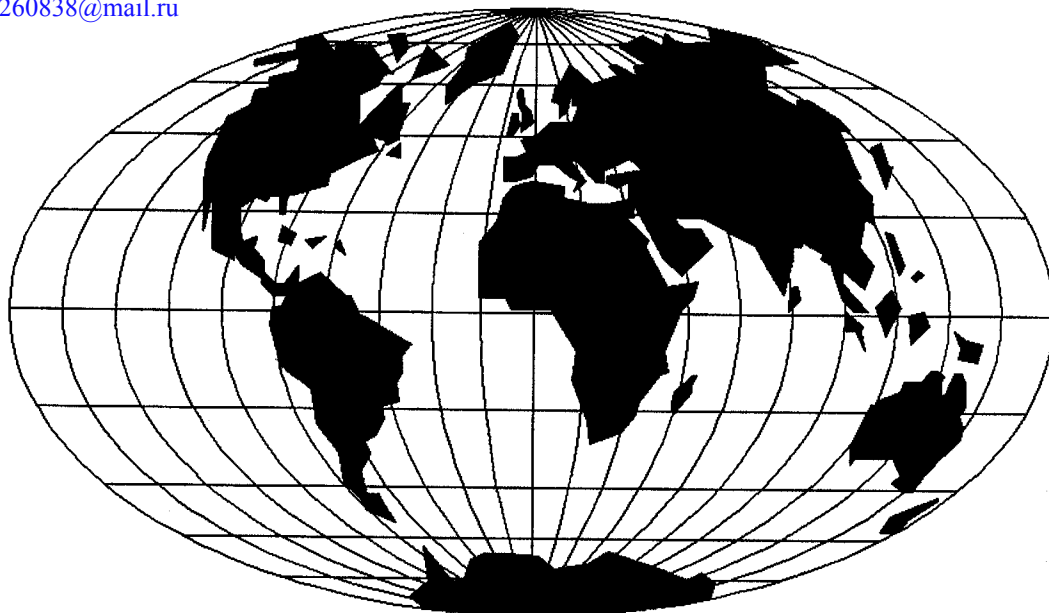

WORLDWIDE SALES AND SERVICE
WELTWEITER VERKAUF UND KUNDENDIENST

Union Special maintains sales and service facilities throughout the world. These offices will aid you in the selection of the right sewing equipment for your particular operation. Union Special representatives and service technicians are factory trained and are able to serve your needs promptly and efficiently. Whatever your location, there is a qualified representative to serve you.

Corporate
Office:

Union Special Corporation
One Union Special Plaza
Huntley, IL 60142
Phone: US: 800-344 9698
Phone: 847-669 4200
Fax: 847-669 4355
www.unionspecial.com

European Distribution Center:

Union Special GmbH
Raiffeisenstrasse 3
D-71696 Möglingen, Germany
Tel.: 49 (0)7141/247-0
Fax: 49 (0)7141/247-100
www.unionspecial.de

Union Special unterhält Verkaufs- und Kundendienst-Niederlassungen in der ganzen Welt. Diese helfen Ihnen in der Auswahl der richtigen Maschine für Ihren speziellen Bedarf. Union Special Vertreter und Kundendiensttechniker sind in unseren Werken ausgebildet worden, um Sie schnell und fachmännisch zu bedienen.

 **Union Special**[®]
Finest Quality